



European Network of
Transmission System Operators
for Electricity

OPERATIONAL RESERVE AD HOC TEAM REPORT

FINAL VERSION

WORKING DRAFT FOR THE PURPOSE OF FACILITATING AD HOC TEAM DISCUSSION
WITHIN THE CONTEXT OF THE FUTURE NETWORK CODE LFC&R
VERSION 6

Disclaimer

This version is a *final version* as of 23/05/2012. It illustrates the set of criteria, requirements and dimensioning for synchronous systems currently under discussion within ENTSO-E. It does not in any case represent a firm, binding and definitive ENTSO-E position.

Executive Summary

The Ad-hoc Team Operational Reserves has been established under the aegis of the System Operations Committee to develop a common approach regarding the determination of the dimension of operational reserves by European TSO. The paper analyses the three pan-European harmonised processes “**Frequency Containment**”, “**Frequency Restoration**” and “**Replacement**”.

The following types of reasons for system frequency deviations have to be separated / considered:

- disturbance / outage of generation, load, and HVDC interconnector
- stochastic imbalances in normal operation
- market driven imbalances – e.g. ramping at the hour shift
- network splitting

These types of reasons for system frequency deviations have to be taken into account for the correct dimensioning of reserves. As a medium term target model, market driven imbalances should be mitigated by integrated measures taken with market participants.

The duration of the system frequency deviation is an important parameter. Whereas the stochastic and the market driven imbalances are **transient** and vanish after some minutes the imbalance caused by a disturbance / outage or even network splitting is **persistent** and has to be covered permanently by an appropriate amount of operational reserves.

With regards to the **persistent** power imbalances, the disturbance / outage of generation or load or HVDC interconnector is taken into account. The basic dimensioning criterion of the **Frequency Containment Reserve (FCR)** is to withstand the **reference incident** in the synchronous area by containing the system frequency within the maximum system frequency deviation and stabilizing the system frequency within the maximum steady-state system frequency deviation.

The reference incident shall be sized taking into account the maximum expected instantaneous power deviation between generation and demand in the synchronous area. In the future the development of dispersed generation will have to be taken into account when defining the reference incident. In very large systems such as RGCE an N-2 scaling criterion of the two biggest generation / consumption / in-feed units shall also be considered for dimensioning the reference incident to scale the risk of multiple outages within the recovering window of the system. This concept is supported by a probabilistic assessment for the calculation of the reference incident.

With regards to **Frequency Restoration Reserve (FRR)** a TSO shall ensure it has access to sufficient reserves to cope with incidents occurring within its control area according to the rules of the synchronous area. The **dimensioning incident** is defined as the maximum expected instantaneous power deviation between generation and demand in a control area. In the future the development of dispersed generation will have to be taken into account when defining the dimensioning incident. The dimensioning incident determines the minimum required volume of FRR to cope with instantaneous failures within the control area.

TSOs are allowed to perform cross-border exchange of reserves with other TSOs or to share reserves in order to cope with the dimensioning incident under defined conditions. In this case congestions and the respective probability of being short of FRR due to FRR exchange limitations have to be taken into account. This issue has to be addressed within the reserve dimensioning. In case of reserve sharing the final responsibility to cope with the dimensioning incident remains with the TSO affected by the incident.

With regards to the **transient** power imbalances as a recommended quality target for a synchronous area the number of 1-minute time units with an average system frequency outside a given band is measured. A target value is defined per synchronous area per year.

A probabilistic assessment shows the consequences of poor system frequency quality by calculating the risk of using up all the FCR available by the combination of a market induced system frequency deviation prior to an imbalance due to a large generation trip. Such scenario could lead to the exhaustion of the FCR without stopping the system frequency fall. One of the main results of this probabilistic assessment is to emphasize the urgent need to adapt market design in order to mitigate the market induced imbalances. This is considered to be a more efficient and desirable objective than to increase the amount of FCR.

With the existing level of market induced system frequency deviations in both synchronous areas analysed the dimensioning criteria for the FCR may not be sufficient to assure an appropriate level of security. The AHT OR recommends fixing the risk in terms of number of years between incidents derived from the lack of FCR due to both – generation trips and market induced imbalances. The assessment of this real risk is recommended to be done on a yearly basis based on the newest system frequency and generating unit data. If it is detected that the real risk is higher than the risk policy until the market design is changed to reduce the market induced imbalances it can be considered to increase the amount of FCR to lower the real risk below the risk policy.

With regards to the **transient** power imbalances relevant for FRR and RR an observation time frame is defined in the magnitude of the time to restore system frequency (e.g. 15 minutes). As a recommended quality target for a synchronous area the percentage of observation time units outside a given frequency band is measured. A target value is defined per synchronous area against which this number is evaluated.

In large synchronous areas like RGCE, a de-central load-frequency-control of control blocks is applied. To satisfy the desired overall system frequency quality in this case the ACE of the individual control blocks must to be kept within defined limits on a continuous basis. A methodology is recommended to calculate individual ACE target values per control block from the overall system frequency quality target of the synchronous area.

Operational standards are key elements for the application of operational reserves. Five relevant categories (1-performance, 2-operational rules, 3-dimensioning, 4-exchange of reserves, 5-monitoring) of operational standards have to be taken into account. The target of defining the right dimension of operational reserves per TSO cannot be solved by a single formula but has to take into account all these five categories (“5-pillar-approach”). It is an iterative procedure starting with the definition of performance indicators, dimensioning the operational reserves and monitoring the results. Afterwards the dimension has to be reconsidered taking into account the results of the monitoring and the underlying performance indicators, operational rules and cross-border exchange of reserves.

Although according to the 5-pillar-approach there is no direct link to calculate the needs for FRR and RR. There are state-of-the-art methodologies that can support the choice of the right level of these reserves. An overview, especially for the well accepted statistical and simulator approaches for reserve dimensioning, is given in the document. The application of these methodologies by the TSO is recommended but not mandatory.

One essential aspect of keeping the power equilibrium is the management of the flows induced for this purpose. The reserve products and the processes for reserve activation, including the cross border exchange, have to be designed accordingly. Rules for **cross-border exchange of reserves, sharing of reserves** and the **distribution of reserves** are elaborated in this document.

Cross-border exchange of reserves is defined as a TSO (“Reserve Receiving TSO”) getting access to operational reserves connected to another grid within the responsibility of another TSO (“Reserve Connecting TSO”) to perform its individual load frequency control. In this case all “Reserve Transiting TSOs” have to be consulted. Cross-border Exchange of reserve leads to an operational interference between the “Reserve Receiving TSO”, “Reserve Transiting TSOs” and the “Reserve Connecting TSO”.

Reserve sharing is a TSO-TSO agreement that allows TSOs under certain conditions to share part of their reserves between each other. TSOs can take shared reserves, made available to them, into account in order to meet individual reserve requirements. The main difference between “Reserve Sharing” and “Exchange of Reserve” is that exchange of reserves is exclusively available to one TSO, while shared reserves are available to more than one TSO.

For reserve sharing, it is recommended to establish a notification procedure for the agreements aiming at verifying that reserve sharing does not jeopardize system security and that the network is able to transmit the flows resulting from the activation of shared reserves.

A basic volume of FRR should at all times be exclusively available to a TSO and must be located geographically within its control area. This basic volume of FRR cannot be shared amongst TSOs.

The “Distribution of Reserves” is independent from the question of “Cross-Border Exchange of Reserves” or “Reserve Sharing”. It gives rules (if necessary) for the distribution of reserves inside a grid or a synchronous area. For FCR it is recommended a distribution based on net generation and consumption.

Table of Contents

| | | |
|-----------|---------------------------------------------------------------------------------|-----------|
| 1 | INTRODUCTION | 6 |
| 1.1 | FREQUENCY CONTROL CONCEPT | 6 |
| 1.1.1 | SYSTEM FREQUENCY AND POWER EQUILIBRIUM | 6 |
| 1.2 | OPERATIONAL RESERVES | 7 |
| 1.2.1 | FREQUENCY CONTAINMENT RESERVES (FCR) | 7 |
| 1.2.1.1 | OBJECTIVES | 7 |
| 1.2.1.2 | MEANS | 7 |
| 1.2.1.3 | HIERARCHY | 7 |
| 1.2.2 | FREQUENCY RESTORATION RESERVES (FRR) | 7 |
| 1.2.2.1 | OBJECTIVES | 7 |
| 1.2.2.2 | MEANS | 8 |
| 1.2.2.3 | HIERARCHY | 8 |
| 1.2.3 | REPLACEMENT RESERVES (RR) | 8 |
| 1.2.3.1 | OBJECTIVES | 8 |
| 1.2.3.2 | MEANS | 8 |
| 1.2.3.3 | HIERARCHY | 8 |
| 1.2.4 | KINDS OF OPERATIONAL RESERVE AND SOURCING | 8 |
| 2 | OPERATIONAL STANDARDS | 9 |
| 2.1 | PERFORMANCE INDICATORS | 9 |
| 2.2 | OPERATIONAL RULES | 9 |
| 2.3 | DIMENSIONING | 10 |
| 2.4 | EXCHANGE OF RESERVES | 10 |
| 2.4.1 | BASIC SCENARIO | 10 |
| 2.4.2 | CROSS-BORDER EXCHANGE OF RESERVES | 10 |
| 2.4.3 | RESERVE SHARING | 10 |
| 2.4.4 | DISTRIBUTION OF RESERVES | 10 |
| 2.4.5 | CROSS-BORDER EXCHANGE OF RESERVES BETWEEN SYNCHRONOUS AREAS | 10 |
| 2.5 | MONITORING | 11 |
| 3 | FREQUENCY CONTAINMENT RESERVE REQUIREMENTS | 11 |
| 3.1 | DESCRIPTION AND TECHNICAL CONCEPT | 11 |
| 3.1.1 | GENERAL CONCEPT | 11 |
| 3.1.2 | FREQUENCY QUALITY PARAMETERS | 13 |
| 3.1.3 | FREQUENCY CONTAINMENT RESERVE PARAMETERS | 13 |
| 3.1.4 | SYSTEM CHARACTERISTICS | 13 |
| 3.1.5 | HARMONIZATION OF PARAMETERS | 13 |
| 3.2 | TARGET AND PERFORMANCE INDICATORS | 16 |
| 3.3 | DIMENSIONING OF FCR | 16 |
| 3.3.1 | REFERENCE INCIDENT | 16 |
| 3.3.2 | INFLUENCE OF THE FREQUENCY QUALITY | 18 |
| 3.4 | INITIAL RESERVE DISTRIBUTION | 19 |
| 3.5 | REDISTRIBUTION OF FCR | 20 |
| 4 | FREQUENCY RESTORATION RESERVE AND REPLACEMENT RESERVE REQUIREMENTS | 21 |
| 4.1 | DESCRIPTION AND TECHNICAL CONCEPT | 21 |
| 4.1.1 | GENERAL CONCEPT | 21 |
| 4.2 | TARGET AND PERFORMANCE INDICATORS | 22 |
| 4.2.1 | TARGET | 22 |
| 4.2.2 | DIMENSIONING INCIDENT | 23 |
| 4.2.3 | MONITORING THE QUALITY TARGET | 24 |
| 4.2.3.1 | FREQUENCY AS UNIQUE PERFORMANCE INDICATOR | 24 |
| 4.2.3.2 | ACE AS DE-CENTRAL PERFORMANCE INDICATOR | 24 |
| 4.3 | METHODOLOGIES FOR RESERVE DIMENSIONING | 25 |
| 4.3.1 | STATISTICAL METHODOLOGY FOR RESERVE DIMENSIONING | 25 |
| 4.3.1.1 | RELEVANT INPUT DATA | 26 |
| 4.3.2 | SIMULATION METHODOLOGY FOR RESERVE DIMENSIONING | 27 |
| 4.3.3 | STATISTICAL ANALYSIS OF CONTROL BLOCK IMBALANCES | 27 |
| 4.3.3.1 | ANALYSIS OF OPEN-LOOP ACE | 28 |
| 4.3.3.2 | ANALYSIS OF THE FAST CHANGING AND UNPREDICTABLE PART OF THE OPEN-LOOP ACE | 28 |
| 4.4 | EXCHANGE, SHARING AND DISTRIBUTION OF RESERVES | 30 |
| 4.4.1 | CROSS-BORDER EXCHANGE OF RESERVES | 30 |
| 4.4.2 | SHARING OF RESERVES | 31 |
| 4.4.3 | DISTRIBUTION OF RESERVES | 31 |
| A. | MAPPING PROCESSES TO PRODUCTS | 33 |

| | | |
|-----------|----------------------------------------------------------------------------------------------------------------------------------------|-----------|
| B. | FREQUENCY DISTRIBUTIONS IN EUROPE | 34 |
| C. | PROBABILISTIC CALCULATIONS ON FREQUENCY CONTAINMENT RESERVE DIMENSIONING AND TARGET PERFORMANCE | 34 |
| C.1. | DIMENSIONING OF THE REFERENCE INCIDENT | 34 |
| C.2. | NUMBER OF MINUTES OUTSIDE THE STANDARD FREQUENCY BAND | 37 |
| C.2.1. | INTRODUCTION..... | 37 |
| C.2.2. | PROBABILISTIC METHODOLOGY TO CALCULATE THE RISK ASSOCIATED TO FREQUENCY DEVIATIONS DUE TO CAUSES OTHERS THAN GENERATION TRIPPING. | 38 |
| C.2.3. | NUMBER OF MINUTES OUTSIDE THE STANDARD FREQUENCY DEVIATION AND RISK OF NEEDING MORE FCR THAN AVAILABLE. | 39 |
| C.2.4. | INFLUENCE OF UNIT SIZE IN THE RISK OF NEEDING MORE THAN THE AVAILABLE FCR..... | 42 |
| C.2.5. | INFLUENCE OF THE REAL NETWORK POWER FREQUENCY CHARACTERISTIC IN THE RISK OF NEEDING MORE THAN THE AVAILABLE FCR FOR RG CE. | 42 |
| C.2.6. | 2.6 INFLUENCE OF THE SPEED OF DEPLOYMENT OF FRR IN THE RISK OF NEEDING MORE THAN THE AVAILABLE FCR FOR RG CE. | 43 |
| C.2.7. | INFLUENCE OF THE PROBABILITY OF DEPLOYMENT OF FRR IN THE RISK OF NEEDING MORE THAN THE AVAILABLE FCR FOR RG CE. | 44 |
| C.2.8. | CALCULATIONS FOR REGIONAL GROUP NORDIC. | 45 |
| C.2.9. | CALCULATIONS FOR REGIONAL GROUP IRELAND..... | 47 |
| D. | IMPACT ANALYSIS INITIAL DISTRIBUTION FCR..... | 50 |
| E. | CURRENT SITUATION CONCERNING CROSS-BORDER EXCHANGE OF RESERVES IN RGCE | 50 |
| F. | ACE TARGET VALUES FOR RGCE..... | 52 |
| F.1. | GENERAL FORMULAS | 52 |
| F.2. | CONCEPT OF OPEN LOOP ACE | 53 |
| F.3. | CONCEPT OF AN ELEMENTARY CONTROL AREA..... | 53 |
| F.3.1. | CASE 1 "INNER CORRELATION = 1" | 53 |
| F.3.2. | CASE 2 "INNER CORRELATION = 0" | 54 |
| G. | GLOSSARY | 55 |

1 Introduction

The Ad hoc Team Operational Reserves (hereinafter “AhT OR”) has been established under the aegis of the System Operations Committee (hereinafter “SOC”). It has the objective to develop and promote the secure and safe operation of the pan-European power network, develop a common approach regarding the determination of the dimension of operational reserves by European TSOs.

1.1 Frequency Control Concept

1.1.1 System Frequency and Power Equilibrium

In any electric system, the active power has to be generated at the same time as it is consumed. Power generated must be maintained in constant equilibrium with power consumed / demanded, otherwise a power deviation occurs. Disturbances in this balance, causing a deviation of the system frequency from its set-point values, will be offset initially by the kinetic energy of the synchronous rotating generating units and motors connected.

There is only very limited possibility of storing electric energy as such. It has to be stored in other types of energy before its transformation to electrical energy such as potential energy in water reservoirs or as chemical energy in coal, oil or gas reservoirs. In some cases this conversion is reversible and electricity can be converted to potential energy (hydro pump stations) or in chemical energy (e.g. battery packs) for small systems. In any case, this is insufficient for controlling the power equilibrium in real-time, so that the system must have sufficient access to reserve providing units to restore the equilibrium. It must be able instantly to handle changes in demand, generation and network configuration (e.g. outages of transmission elements).

The system frequency is a representative value for the rotation speed of the synchronised generating units. System frequency is a common property with an equal value in the whole synchronous area and the responsibility of maintaining it within the agreed limits is shared by all TSOs in that area. The actual system frequency value is a consequence of the power balance between generation and load resulting from all simultaneous events and actions of all system users, system inertia system static characteristics and activation of operational reserves. The following aspects have to be taken into account:

- Stable system frequency is a common good for all system users, but no (tradable) commodity.
- Deviations from the nominal frequency value may jeopardize normal operating conditions.
- Both, size and duration of the system frequency deviations must be limited.

Responsibility for defining and providing stable system frequency is assigned to all TSOs in the synchronous area:

- Frequency Containment is a joint responsibility distributed among all TSOs in the synchronous area.
- Frequency Restoration is a local responsibility only of the imbalanced TSO.
- The task of system control for a synchronous area is to keep the system frequency within a defined range.

The following types of reasons for system frequency deviations have to be separated / considered:

- disturbance / outage of generation or load or HVDC interconnector
- stochastic imbalances in normal operation
- market driven imbalances – e.g. ramping at the hour shift
- network splitting

These types of reasons for system frequency deviations have to be taken into account for the correct dimensioning of reserves. As a medium term target model, market driven imbalances should be mitigated by integrated measures taken with market participants.

The duration of the system frequency deviation is an important parameter. Whereas the stochastic and the market driven imbalances are transient and vanish after some minutes the imbalance caused by a disturbance / outage or even network splitting is persistent and has to be covered permanently by an appropriate amount of operational reserves.

One essential aspect of keeping the power equilibrium is the management of the flows induced for this purpose. The reserve products and the processes for reserve activation, including the cross border exchange, have to be designed accordingly. Rules for cross-border exchange of reserves and the distribution of reserves serve as an example.

1.2 Operational Reserves

1.2.1 Frequency Containment Reserves (FCR)

1.2.1.1 Objectives

Frequency containment aims at the operational reliability of the synchronous area by stabilizing the system frequency in the time-frame of seconds at an acceptable stationary value after a disturbance or incident; it does not restore the system frequency to the set point. The common activation of Frequency Containment Reserve (FCR) in the whole synchronous area modifies the balance between generation and load at the scale of each TSO and hence consequently the power exchanges between the TSOs are varying from their set point.

1.2.1.2 Means

Frequency containment depends on reserve providing units (e.g. generating units, controllable load resources and HVDC cables) made available to the system in combination with the physical stabilizing effect from all connected rotating machines. As generation resource it is a fast-action, automatic and decentralized function e.g. of the turbine governor, that adjusts the power output as a consequence of the system frequency deviation.

1.2.1.3 Hierarchy

Frequency containment reserves are activated locally and automatically at the site of the reserve providing unit, independently from the activation of other types of reserves.

1.2.2 Frequency Restoration Reserves (FRR)

1.2.2.1 Objectives

Frequency restoration aims to restore the system frequency in the time frame defined within the synchronous area by releasing system wide activated frequency containment reserves. For large interconnected systems, where a decentralized frequency restoration control is implemented, frequency restoration also aims to restore the balance between generation and load for each TSO, and consequently restore power exchanges between TSOs to their set point.

1.2.2.2 Means

Frequency restoration depends on reserve providing units made available to the TSOs independently from FCR. Activation of Frequency Restoration Reserve (FRR) modifies the active power set points / adjustments of reserve providing units in the time-frame of seconds up to typically 15 minutes after an incident.

1.2.2.3 Hierarchy

In each control area FRR are activated centrally at the TSO control centre, either automatically or manually.

Frequency restoration must not impair the frequency containment that is operated in the synchronous area in parallel.

1.2.3 Replacement Reserves (RR)

1.2.3.1 Objectives

TSOs need replacement reserves (RR) to prepare for further imbalances in case FCR / FRR has already been activated up to a certain extent, e.g. when market participants have no possibility (neutralisation lead-time) or not the necessary information to compensate by themselves their forecast uncertainties on load, renewable generation, etc.

This amount needed and the time window during which the TSO is restoring the balance on behalf of the market players is highly depending on the market design of each country.

Replacement reserves are activated manually and centrally at the TSO control centre in case of observed or expected sustained activation of FRR and in the absence of a market response. TSO can also use RR to anticipate on expected imbalances.

1.2.3.2 Means

Replacement reserves depend on reserve providing units made available to the TSOs, independently from FCR or FRR.

1.2.3.3 Hierarchy

It is used to release FCR and FRR or to prevent its activation in normal operation.

1.2.4 Kinds of Operational Reserve and Sourcing

The relationship between the different kinds of operational reserves and the sourcing is complex (see Figure 2). The possibilities for reserve sourcing depend on the technical characteristics of the synchronous system and the local market design. The possible alternatives are:

- ex-ante procurement of firm reserve capacity available for the TSO
- Activation from market participants without ex-ante procurement (balancing market)

Figure 1 below gives a general overview of the current relationship between types of operational reserves and sourcing.

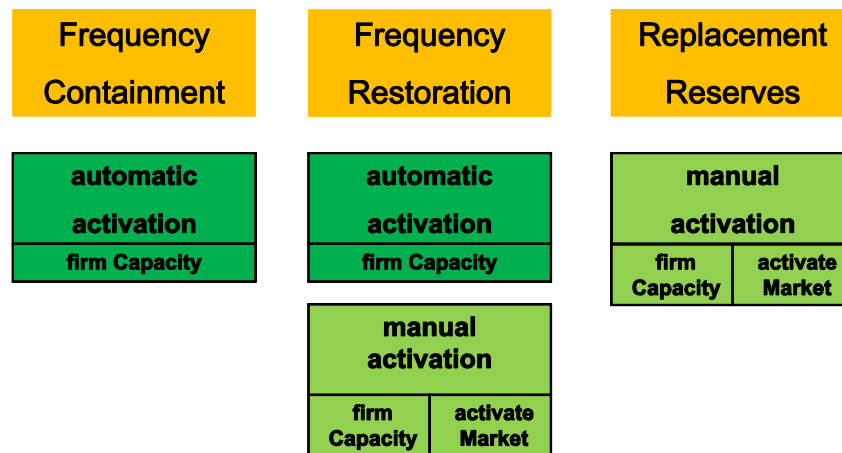
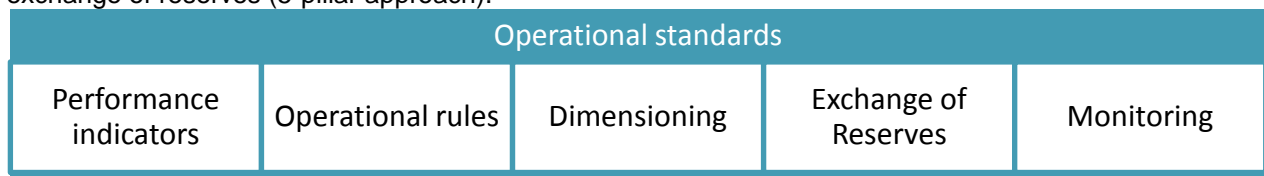

Figure 1: Kinds of Operational Reserve and Sourcing

2 Operational standards

Operational standards are key elements for the application of operational reserves. Five relevant categories of operational standards have to be taken into account. The target of defining the right dimension of operational reserves per TSO cannot be solved by a single formula but has to take into account all these five categories. It is an iterative procedure starting with the definition of performance indicators, dimensioning the operational reserves and monitoring the results. Afterwards the dimension has to be reconsidered taking into account the results of the monitoring and the underlying performance indicators, operational rules and cross-border exchange of reserves. Dimensioning of reserves has to be secured in each time horizon of the TSO operational planning.

The AhT OR first defines per reserve category common targets and common performance indicators which form the basis for the operational reserve dimensioning in terms of target quality. On this basis it provides per kind of reserve approaches for dimensioning operational reserves on the basis of these performance indicators and defines the framework of how to take into account the cross-border exchange of reserves (5-pillar approach).



2.1 Performance Indicators

Performance indicators are metrics enabling to evaluate the fulfilment of the targets defined per reserve category such as e.g. the system frequency quality and the performance of frequency and load frequency control (LFC). For the purpose of operational reserves dimensioning, specific performance indicators and target values with respect to FCR, FRR and RR have to be defined. The definitions of the performance indicators will be harmonised among all ENTSO-E members, whereas the choice of the target values will inevitably respect the diversity of system characteristics across Europe (particularly the size of synchronous areas).

The performance indicators and the respective target values can be based on a statistical approach (i.e. standard deviation of system frequency) or on a deterministic approach (i.e. N-1 rule). Definitions of a basic recommended set of performance indicators are introduced per reserve category.

2.2 Operational Rules

Operational rules define a concept of frequency and load frequency control, including the required design of automatic FRR and rules for control action coordination among TSOs in large synchronous areas. They are essential not only for a secure real time system operation but also for the effective

operational reserve dimensioning. These operational rules are part of the current Operational Codes like the Operation Handbook, Network Codes etc. but outside the scope of this work.

2.3 Dimensioning

Operational reserve requirements define the ability to cope with situations that occur under normal system operation conditions as well as in case of disturbances to the system, in which case these requirements improve the capability of the system to return to a normal operation condition and avoid the aggravation of a disturbance to an emergency situation or even black-outs. Each TSO shall dimension the operational reserves required for its area of responsibility.

2.4 Exchange of Reserves

The development of cross-border exchanges of reserves is essential to optimise procurement and activation of reserves and to support the efficient integration of renewable energy. The analysis of the possibilities and limitations of such exchange is performed per reserve category. For this the following terms have to be distinguished:

2.4.1 Basic Scenario

A TSO responsible for the load frequency control with access to operational reserves connected to its grid (the “Reserve Receiving TSO” equals the “Reserve Connecting TSO”)

2.4.2 Cross-border Exchange of Reserves

A TSO (“Reserve Receiving TSO”) gets access to operational reserves connected to another grid within the responsibility of another TSO (“Reserve Connecting TSO”) to perform its individual load frequency control. In this case all “Reserve Transiting TSOs” have to be consulted. In terms of FCR the concept of Reserve Transiting TSO is already taken into account in the proposal of redistribution of these reserves. Reserve Transiting TSO is the TSO affected by the power flows resulting from the activation of reserves in Reserve Connecting TSO up to a predefined level as it is predefined for a synchronous area. Cross-border Exchange of reserve leads to an operational interference between the “Reserve Receiving TSO”, “Reserve Transiting TSOs” and the “Reserve Connecting TSO”.

2.4.3 Reserve Sharing

Reserve sharing is a TSO-TSO agreement that allows TSOs under certain conditions to share part of their reserves between each other. TSOs can take shared reserves, made available to them, into account in order to meet individual reserve requirements. The main difference between “Reserve Sharing” and “Exchange of Reserve” is that exchange of reserves is exclusively available to one TSO (see section above), while shared reserves are available to more than one TSO.

2.4.4 Distribution of Reserves

The “Distribution of Reserves” is independent from the question being in the “Basic Scenario”, “Cross-Exchange of Reserves” or “Reserve Sharing”. It gives rules (if necessary) for the distribution of reserves inside an area or a synchronous area.

2.4.5 Cross-border Exchange of Reserves between Synchronous Areas

This definition is analogous with the “Cross-border Exchange of Reserves” with the particular property that it leads to an operational interference between the synchronous areas involved.

2.5 Monitoring

- Monitoring is an essential part of the provision and performance of operational reserves as it assures that the standards are followed by all TSOs involved.
- Guidelines for monitoring should be provided so that it is done in a harmonized way.
- Monitoring shall include common quality parameters (system frequency) as well as individual parameters for TSOs.
- Process on how to perform the monitoring should be made available to all TSOs.
- The results of the monitoring should be declared to a common TSO body per synchronous area for analysis.
- Criteria compliance reporting - all criteria will be evaluated and compare to its requested values.

Due to the mutual influence by and on all interconnected TSOs, each control block / TSO ought to be subject to evaluation and reporting, on several levels (i.e. ENTSO-E, synchronous area, TSO).

3 Frequency Containment Reserve Requirements

3.1 Description and Technical Concept

3.1.1 General Concept

Disturbances are deviations that impair the equilibrium of generation and demand will cause a system frequency deviation, to which the FCR controller of reserve providing units involved in FCR control will react at any time immediately, thereby ensuring that the system frequency is maintained within defined limits. In case that the system frequency exceeds these permissible limits, additional measures out of the scope of the FCR controller, such as (automatic) load shedding, are required and carried out in order to the maintain interconnected operation.

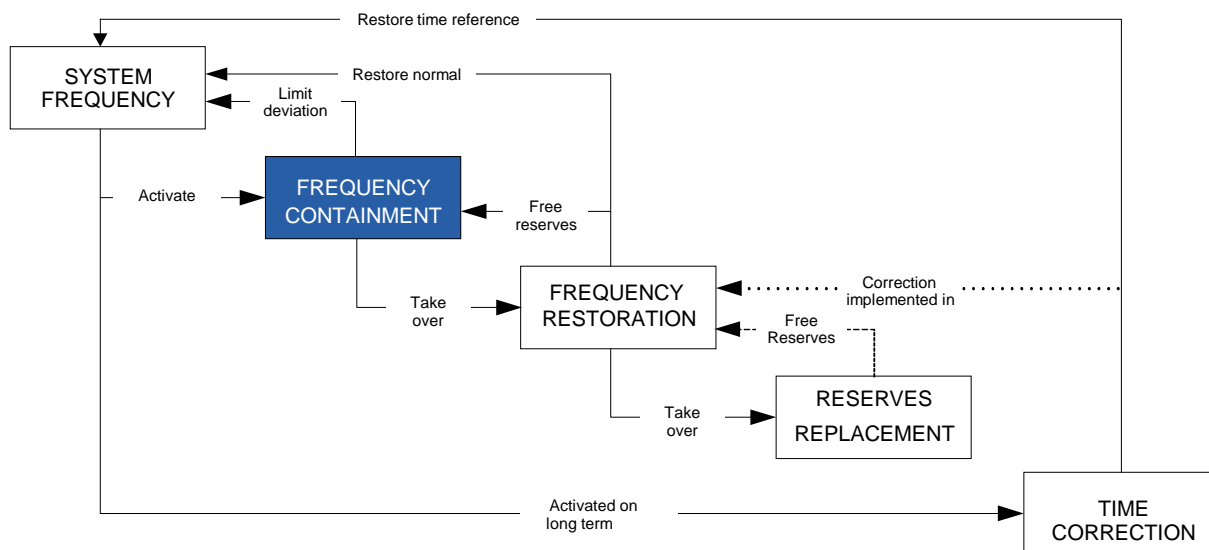

Figure 2: FCR and interaction between operational reserves

Any system frequency deviation beyond a certain insensitivity range will cause the FCR controller of all the involved reserve providing units to respond within a few seconds. The controllers correspondingly start to alter the power output of the reserve providing units and continue to adapt the power output as long as the system frequency continues to change. As soon as the balance is re-established, the

system frequency stabilizes and remains at a quasi-steady-state value. This new stable value will differ from the frequency set-point because of the activation principle of FCR (reserve providing units' droop).

Since not only the reserve providing units in the area the imbalance occurred will participate but all reserve providing units in the synchronous area (principle of joint action in the synchronous area), cross-border exchanges in the interconnected system will also differ from their set point (i.e. exchange schedules).

It is the basic principle of FCR to directly react on system frequency deviations based on a (theoretically) linear correlation. Thus, all frequency quality parameters that reflect the return of system frequency and / or power exchanges to the set point value or parameters like mean values of the system frequency cannot be influenced by FCR and are linked to the deployment of FRR. Requirements on FCR in general can only influence the frequency quality parameters that are connected to system stability criteria.

Corresponding to a sudden outage (as an idealized example) the behaviour of system frequency assuming respective controller performance and other system parameters is outlined below.

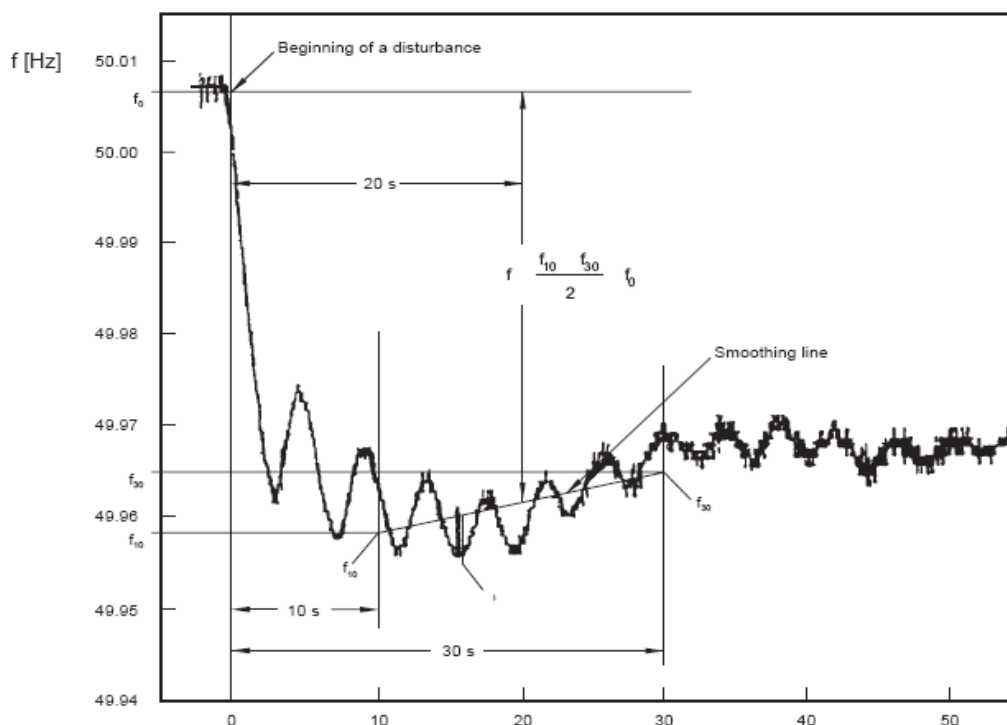

Figure 3: Transient and steady state characteristic¹

The dynamic behaviour of the system frequency is governed mainly by the following:

- the amplitude and development over time of the disturbance affecting the balance between power output and consumption;
- the kinetic energy of rotating machines in the system (system inertia);
- the number of reserve providing units providing FCR, and the amount of FCR available and its distribution;
- all reserve providing units' droop subject to FCR in the synchronous area;
- the dynamic characteristics of the machines (including controllers);
- the dynamic characteristics of loads, particularly the self-regulating effect of loads.

¹ From UCTE Operation Handbook Policy 1 Appendix 1: Load-Frequency Control and Performance.

The FCR must be kept activated until the frequency restoration reserves (FRR) available to the TSO in whose responsibility area the imbalance occurred are deployed returning the system frequency to its set-point value and restoring the FCR.

The following set of parameters is defined to describe the performance of the system in undisturbed state and after a generation-load imbalance:

3.1.2 Frequency Quality Parameters

- *Nominal Frequency*: The rated value of the system frequency for which all equipment connected to the electrical network is designed.
- *Standard frequency range*: Frequency range within which the system should be operated for defined time intervals. It is used as a basis for frequency quality analysis.
- *Standard frequency criterion*: Maximum time intervals where the system frequency of a synchronous area is allowed to be outside the standard frequency range without demand for remedial actions
- *Maximum frequency deviation*: Maximum expected instantaneous system frequency deviation after the occurrence of a reference incident assuming predefined system conditions.
- *Maximum steady-state frequency deviation*: Maximum expected system frequency deviation at which the system frequency oscillation after the occurrence of a reference incident stabilizes assuming predefined system conditions.
- *Time to restore frequency*: Maximum expected time after the occurrence of a reference incident in which the system frequency is restored inside the tolerance range for FCR activation.
- *Electrical time deviation*: Time discrepancy between synchronous time and UTC.
- *Maximum electrical time deviation*: maximum deviation of the system time (the time integral of the system frequency) from the astronomical time (UCT), agreed by TSO of the synchronous area.

3.1.3 Frequency Containment Reserve Parameters

- *Reference incident*: The maximum expected instantaneous power deviation between generation and demand in the synchronous area in Megawatt for which the dynamic behaviour of the system is designed.
- *Tolerance range for FCR activation*: System frequency deviation at which the FCR activation is triggered at the latest.
- *Full activation deviation for FCR*: System frequency deviation at which the FCR are fully activated.
- *Activation delay of FCR*: Time delay between the occurrence of system frequency deviations bigger than the activation deviation of FCR and the start of activation of FCR.
- *Full activation time of FCR*: Time period between the occurrence of the reference incident (idealized step-shaped) and the corresponding full activation of the FCR.

3.1.4 System Characteristics

- *Self-Regulation of Load*: Load decrease assumed in case of a system frequency drop of 1 Hz.
- *System Time Constant*: Time constant of the dynamic response of the synchronous system assuming it behaved as a first order filter after the occurrence of a generation-load imbalance.

3.1.5 Harmonization of Parameters

A possible harmonization of FCR parameters for different synchronous areas is in many aspects limited due to the individual characteristics of the synchronous areas due to the influence of system inertia and the size of its generating units or HVDC interconnectors compared to the size of the system. This is particularly true if the target values of the parameters for small synchronous areas with relatively large generating units and target values of large synchronous areas should be harmonized. In general, small

areas are much less robust as bigger ones in case of disturbances / imbalances just due to physical reasons.

However, it is possible and desirable that the definitions of the parameters are harmonized in all of the synchronous areas. The methodology for FCR dimensioning should be the same in all synchronous areas as well.

With the aim of creating a single, unified electricity market it is also appropriate to harmonize the requirements for reserve providing units, as far as it is technically feasible, especially those that determine their behaviour when deploying FCR.

Taking into account the different size and technical characteristics of the different synchronous areas on the one hand and the targeted unique ENTSO-E wide requirements for reserve providing units on the other hand, different values for the frequency parameters for the synchronous areas result as a matter of fact.

The following table shows the values for the parameters in the different synchronous areas:

| | Baltic* * for whole synchronous operating area | Continental Europe | Great Britain | Ireland | Nordic | Cyprus |
|--------------------------------------------------------------------------------|--------------------------------------------------------------------------------------------------------------------------|----------------------|----------------------------------------------------|--------------------|----------------------------------------------|------------------------------------|
| Nominal frequency | 50 Hz | 50 Hz | 50 Hz | 50 Hz | 50 Hz | 50 Hz |
| Standard frequency deviation range | ±50 mHz normal range ±200 mHz permissible range | ±50 mHz ² | ±200 mHz | ±200 mHz | ±100 mHz | ±200 mHz |
| Max number of minutes for deviation outside standard frequency deviation range | 95 % of the time inside ±200 mHz range and no more than 5 % of the time (72 minutes /per 24 h) inside ±200-400 mHz range | No | No | No | Less than 10000 min/y | No |
| Maximum frequency deviation | ±800 mHz | ±800 mHz | ±800 mHz | ±1000 mHz | ±500 mHz | ±1200 mHz |
| Maximum quasi-steady-state frequency deviation | ±200 mHz | ±200 mHz | ±500 mHz | ±500 mHz | ±500 mHz | ±500 mHz |
| Reference incident | 1200 MW | 3000 MW | Depends on if "normal" or "infrequent" infeed loss | The largest infeed | Biggest unit in operation, calculated weekly | Biggest unit in operation (130 MW) |

² Under consideration by the RGCE SG SF

| | | | | | | |
|------------------------------------|-------------------------------------------------------|----------|---------------------------------------------------------------|------------------------------------------|---------------------------------------------|-----------------|
| Time to restore frequency | 15 min | 15 min | 49.5 Hz within 1 min | 49.5 Hz within 1 min | 15 min | 20 min |
| Maximum electrical time deviation | ±30 s | ±30 s | Not a legal requirement although it is monitored (±30 sec) | in normal circumstances not exceed ±10 s | ±30 s | ±30 s |
| Tolerance range for FCR activation | ±20 mHz for normative FCR ±150 mHz for general FCR | ±20 mHz | ±15 mHz | ±15 mHz | | 150-200 mHz |
| Full activation deviation for FCR | ±200 mHz for normative FCR | ±200 mHz | ±500 mHz | ±200 mHz | ±100 mHz (normal) -500 mHz (disturbance) | ±200 mHz- |
| Full activation time of FCR | 30 s for normative FCR | 30 s | 10 s for "primary response" and 30 s for "Secondary Response" | 90 s | 3 min (normal) 30 s (disturbance) | No requirements |

Table 1: Operational reserve parameters for the difference synchronous systems

Regarding these values, there are additional considerations that need to be taken into account:

- **Activation delay of FCR:** Immediate activation after the occurrence of an imbalance is recommended; therefore the activation delay of FCR should be zero (no active dead time).
- **Maximum absolute frequency deviation:** In order to prevent any activation of the under-frequency load-shedding relays when a reference incident occurs, a security margin should be established between the maximum instantaneous system frequency deviation and the frequency setting of the first step of unwanted load shedding due to under-frequency. This security margin should take into account:
 - Possible stationary system frequency deviations before an incident
 - Insensitivity of turbine controller and inaccuracy of frequency measurement
 - Larger dynamic system frequency deviation at the site of the incident, not taken into account in the specific network model used for simulations
 - Any other possible alteration with respect to the design criteria: inertial behaviour of the synchronous area, speed of deployment of FCR, etc.
- **Maximum steady-state frequency deviation (= full activation deviation for FCR):** At the maximum steady-state system frequency deviation FCR must be fully activated. The droop of all reserve providing units participating in FCR should be set in such a way that all the contracted/obligatory FCR are deployed.
- **Time to restore frequency:** The specified duration of the full deployment of FCR must be at least the time to restore system frequency in order to maintain system balance and frequency stability until the FRR are deployed. Once sufficient FRR are deployed to return the system frequency to the band defined by the tolerance range for FCR activation, the FCR will be restored and therefore no longer needed until the next imbalance.
- **System time constant:** A minimum/maximum synchronous area time constant could be set as if it behaved dynamically as a first order filter after the occurrence of a generation-load imbalance (e.g. 10 to 20 s). The dynamic response of the system can differ from the theoretical linear law $P = K(f-f_0)$ just after the occurrence of a system frequency deviation and its dynamic behaviour should be better than the response expected by applying a first order filter characterized by a time constant of a certain value (e.g. 10 to 20 s) to system frequency deviation signal $(f-f_0)$ (t).

3.2 Target and Performance Indicators

The deployment of frequency containment reserves (FCR) maintains the system frequency within the defined permissible values both in normal operation and after the occurrence of an imbalance between generation and load. In order to establish the required dimension of FCR, a common “frequency concept” must be set per synchronous area as a goal to reach which depending on the system and the behaviour of reserve providing units will lead to proper reserve sizing.

The frequency concept of the synchronous area will imply setting target values to the frequency parameters which are described in the previous section. All of these limits apply to parameters that are common for all TSO within a synchronous area.

The target of FCR dimensioning is to avoid the emergency state. For this there has to be in any case sufficient FCR available to cope with pre-defined reference incidents reacting on a power imbalance within the full activation time of FCR. It is recommended for each synchronous area that an appropriate performance indicator is the maximum absolute frequency deviation and the maximum steady-state frequency deviation.

A subordinated requirement aims to keep the FCR available to cope with the reference incident and to protect from FCR deployment due to system frequency quality.

Market induced imbalances occur when changes of generating units/load do not happen simultaneously. E.g. power difference between the continuous ramp-wise physical load behaviour and discontinuous / step wise power generation behaviour (market-rule-based schedule). These “market induced” effects depend to a large extent on the framework conditions of the respective market rules and have more or less regularly led to significant system frequency deviations at the hour shift.

As a recommended quality target for a synchronous area the number of 1-minute time units with an average system frequency outside a given band is measured. A target value is defined per synchronous area per year. The percentage value (rate) is calculated by dividing this count by the total number of 1-minute time units in the observation period. The observation period is typically 1 year. For monitoring purposes shorter time periods are recommended.

In case the system frequency deviation is higher than threshold values defining the emergency state (maximum absolute frequency deviation and maximum steady-state frequency deviation), additional usually automatic actions to decrease the system frequency deviation could be taken. These measures can include:

- Increasing / decreasing the level of generation of active power, e.g. starting/stopping pumped-storage power plants.
- load shedding

Schemes for extraordinary conditions including load shedding schemes should be coordinated on the level of synchronous area and will be dealt with in the Emergency Code in detail. Nevertheless the frequency threshold for the first step of load shedding is a basis for the development of requirements concerning other frequency parameters for “normal” conditions.

3.3 Dimensioning of FCR

3.3.1 Reference Incident

The basic dimensioning criterion of the FCR is to withstand the reference incident in the synchronous area by containing the system frequency within the maximum system frequency deviation and stabilizing the system frequency within the maximum steady-state system frequency deviation. In order to reach the steady-state without activating under or over-frequency relays the FCR shall replace the

generation / load that was lost triggering the event and therefore be dimensioned at least as large as the reference incident. The determination of the reference incident is therefore crucial for the dimensioning of FCR.

The reference incident shall be an event rare enough to assure that any imbalance between generation and demand is with great confidence less severe than it. The total FCR of a synchronous area must be designed in such a way that after the occurrence of an imbalance smaller or equal to the reference incident the system recovers to a safe state without the need for load-shedding.

FCR shall be sized equal or larger than the reference incident to assure that for an imbalance disturbance smaller or equal to the reference incident the system frequency will be stabilized by the deployment of these reserves. In smaller systems, a certain amount of load shedding may be used to stabilize the system after the occurrence of the reference incident due to technical or economic reasons as the speed of the reserve providing units is not fast enough to overcome the system frequency fall due to the small system inertia.

The reference incident shall be sized taking into account at least the loss of the biggest power generation / consumption unit or the loss of a line section, bus bar or HVDC interconnector that may cause the biggest imbalance with an N-1 failure³. In larger systems such as in the Regional Group Continental Europe (RGCE) with many units there is a larger probability of an additional loss of generation, consumption or in-feed before the system has recovered from a previous loss within the design window.

A probabilistic assessment for the calculation of the reference incident is recommended as well as the use of historic data to determine which the largest generation loss was in a certain number of years. In very large systems such as RGCE an N-2 scaling criterion of the two biggest generation / consumption / in-feed units shall be used for dimensioning the reference incident to scale the risk of multiple outages within the recovering window of the system.

As an example, in the RGCE Synchronous Area an N-2 criterion is used leading to determine the size of the reference incident in 3000 MW which is the equivalent to two nuclear power units of 1500 MW, the biggest there are in the system. A probabilistic assessment has been performed taking into account the possibility of the occurrence of multiple events within a short period of time leading to an even greater power imbalance. Such a probabilistic assessment is described in Annex C.

As a result for or the CE system, in a Monte Carlo simulation of 10^8 successive runs the largest imbalance registered was of 2910 MW with the hypotheses described above. It must be noted that in the calculation it has been assumed that the generation trips occur independently from each other except for generating units located in the same plant or that are connected to the network in the same node whereas a number of circumstances (large disturbances, extreme weather conditions, etc.) may occur leading to a simultaneous trip of several units in a short period of time in a different location or connected to a different substation. Furthermore, an unlimited amount of FRR is assumed in the control area where the imbalance occurs. In the case that this assumption is correct only 95 % of the time and there is a probability of 5 % that the FRR in the area where the imbalance occurred is not available until 15 minutes afterwards, the maximum imbalance observed for 10^8 successive runs is of 3200 MW. Moreover, the study doesn't take into account the loss of contribution to FCR and FRR due to the group which trips.

Therefore 3000 MW seems a reasonable reference incident for RGCE, conservative enough to assure that larger imbalances will be rare, but within reason, assuming that all larger imbalances are caused by generators trips and that the FRR always replaces FCR as designed.

³ It may be necessary in the future to verify the definition of the reference incident because of the changes of the transmission and generation systems (development of dispersed generation).

3.3.2 Influence of the Frequency Quality

Imbalances not associated with unexpected trips of load or generation also cause system frequency deviations which lead to the deployment of some FCR to be compensated. Until the FRR takes over some FCR will be already in use and therefore not ready to counteract the effects of a generating unit/load trip. The larger these system frequency deviations are and the more time it takes to counteract them the more probable it is that a large generation/load imbalance incident occurs when some FCR are deployed leading to an event that will cause the system frequency to surpass the defined limits within the design of the system and possibly to under-frequency load-shedding. The number and length of the system frequency deviations associated to events other than trips must therefore be limited.

A probabilistic assessment shows the consequences of poor system frequency quality by calculating the risk of using up all the FCR available by the combination of a market induced system frequency deviation prior to an imbalance due to a large generation trip. Such scenario could lead to the exhaustion of the FCR without stopping the system frequency fall. The system frequency will then be most likely stabilized by the activation of under-frequency load shedding relays and an unwanted loss of supply to some customers. The needed FCR for the combination of the two events will be the sum of the FCR needed to overcome the initial system frequency deviation and the FCR needed to compensate the sudden generation loss. Simulations have been carried out to show the effect in the RG Continental Europe of the number of minutes outside the 75 mHz band and the risk of using all FCR available. These simulations and conclusions are explained in detail in Annex C.

The results derived from these simulations show that with the 2010 system frequency quality the risk of using all 3000 MW is of 1 in 19.25 years due to the combination of an existing market induced system frequency deviation and an imbalance due to generation trip in the RGCE. In order to obtain this result a perfect behaviour and unlimited availability of the FRR has been assumed. However, this assumption might not be correct in some cases as a control area within a synchronous system might not have FRR available which would imply that the FCR will continue to be deployed until the control area has FRR or RR available. In the case that there is a probability of 5 % that the FRR in the area where the imbalance occurred is not available the risk of needing more than the available 3000 MW of FCR increases to 1 in 9.62 years.

These results are also very sensitive to initial parameters: the variations of the network power frequency characteristic and the speed of deployment of FRR give very different results, as detailed in Annex C.

Similar calculations have been performed for RG Nordic. The available FCR in the Nordic system equals 1600 MW. However, since the self-regulation of loads is considered in RG Nordic for sizing of the FCR, this probabilistic study takes into account 200 MW of additional reserves due to the effect of the self-regulation of loads, totalling 1800 MW. The risk of needing more than 1800 MW of FCR plus self-regulation in the RG Nordic is of 1 in 0.82 year.

However in the last 10 years no significant incident occurred. In reality, many hydro units are running in frequency mode which increases significantly in most cases the available FCR in RG Nordic and therefore decreases the risk of using all that is available. In addition, the HVDC interconnectors with RG Continental Europe are providing also frequency response for large system frequency deviations in RG Nordic. These effects have not been taken into account in these probabilistic studies and the real risk is certainly much lower

These calculations have been also performed for RG Ireland. The assumed available FCR in the Irish system is 470 MW plus 90 MW due to the effect of the self-regulation of loads (1.5 %/Hz), totalling 560 MW. The risk of needing more than 560 MW of FCR plus self-regulation is of 0.0000023 or 1 in 8.25 years. It must be noted however that it is believed that such a probabilistic methodology can't be directly applicable to smaller systems in which all of the generators are running in frequency responsive mode at all times without distinguishing which part of the available reserve in them is FCR and which

part is FRR. Therefore the simulations for RG Ireland have been performed only for comparison with the larger systems and illustration purposes.

With the existing level of market induced system frequency deviations in both synchronous areas analysed the dimensioning criteria for the FCR may not be sufficient to assure an appropriate level of security. The AhT OR recommends fixing the risk in terms of number of years between incidents derived from the lack of FCR due to both – generation trips and market induced imbalances. The assessment of this real risk is recommended to be done on a yearly basis based on the newest system frequency and generating unit data. If it is detected that the real risk is higher than the risk policy until the market design is changed to reduce the market induced imbalances it can be considered to increase the amount of FCR to lower the real risk below the risk policy.

One of the main results of this probabilistic assessment is to emphasize the urgent need to adapt market design in order to mitigate the market induced imbalances. This is considered to be a more efficient and desirable objective than to increase the amount of FCR.

Furthermore the analysis of real data may provide additional monitoring of the risk as it can be considered that when the negative system frequency deviations exceed a threshold without any incident, the N-1 criterion is not respected. For example in RGCE it happened that the threshold of minus 100 mHz was exceeded 22 times during more than one minute in 2011. For the whole year, the total duration of such deviations is about 80 minutes.

3.4 Initial Reserve Distribution

The required volume of FCR is determined on the level of the synchronous area and, frequency containment being a joint responsibility, has to be shared amongst all TSO based on principles of fairness and network security. Each TSO is responsible for the compliance to its initial FCR contribution.

Distribution of FCR relates to a number of aspects important to secure the security of supply:

- The flows resulting from FCR activation have to be managed. A proper distribution of FCR has to be applied for the sake of an appropriate flow management.
- If a reserve providing unit, on which reserve is allocated, trips, the amount of immediate loss of reserve and the drop of network power frequency characteristic have to be limited. As an additional rule, it is proposed to allow a maximum of 3 % of the total FCR to be provided by one reserve providing unit, and a maximum of 6 % per electrical node. For island and small systems higher values may be necessary.
- Risk of insufficient reserve in case of congestion / network splitting should be limited.

FCR has to be ready to cope with any incident in the Synchronous Area leading to a flow through the power network. The “source” of such flows is well determined as the location of the FCR is known whereas the “sink” can be anywhere in the power network. To be able to cope with any flow resulting from any incident in real time there is the general rule that the distribution of FCR should be as even as possible. The key for sharing the FCR amongst TSO gives the initial position. Redistribution of FCR is allowed within some well-defined limits in order to enhance overall economic efficiency (see section 5).

System frequency deviations that offset FCR activation are caused by imbalances between generation and load. The table below summarizes different types of system frequency deviations together with their origin:

| Origin related to: | Types of system frequency deviations | | | |
|--------------------|--------------------------------------|----------------------------|--------------------------|-------------------|
| | Disturbance/outage | Stochastic imbalances | Market driven imbalances | Network splitting |
| Generation | Outage of Generating Units | Generation forecast errors | – | – |

| | | | | |
|-------|-----------------------------------------------------------------------------------------------------------------------------------------------|------------------------------------------------------|---------------------------------------------------------------------|-------------------------------------------------------------------------------------------------------|
| | | (RES, etc.) Variations in Generation output | | |
| Load | Outage of large Load | Load forecast errors Variations in Load | – | – |
| Other | Outage of HVDC interconnectors causing shortage of Generation or Load Network outage causing loss of load or generation | – | Imperfect Load following by Generation due to market rules | Tripping of overloaded interconnection lines causing shortage of Generation or Load |

Table 2: Different type of system frequency deviations

The same simulations as for FCR dimensioning show that for RGCE only a limited share of 18 % of upward FCR activations is due to tripping of generating units. Moreover the above table shows that it is difficult to allocate system frequency deviations either to load or generation, since they are caused by both.

The initial distribution of FCR can therefore be calculated based on net generation and consumption. The share of FCR for each TSO is then determined based on its net generation and consumption compared to the net generation and consumption of the synchronous area. An impact analysis for the initial reserve distribution for RGCE is performed and can be found in Annex C.

The initial distribution based on net generation and consumption fulfils both requirements.

3.5 Redistribution of FCR

A geographical distribution of FCR is needed in order to operate the power network in safe and secure conditions. The initial distribution of FCR defines the sharing of the responsibility for the FCR inside a synchronous area, including the financial obligations of the single TSO. However, a too strict homogeneous distribution would have a negative impact on the efficiency by preventing from locating the reserves on the most economic reserve providers. A redistribution of FCR is possible to enable a cross-border market for FCR. For the redistribution, particular rules for the geographical distribution for FCR have to be taken into account.

Taking into account this context, it is necessary to design minimal requirements for the geographical distribution of reserves making possible both to maintain high standards of security and allow the development of cross-border exchanges.

In case of an imbalance FCR is automatically activated in all reserve providing units. Activated FCR is then – based on physics - delivered to the areas that are not balanced. Consequently respective transport capacity has to be available (TRM for the “base case”) considering the physical parameters:

- geographical distribution of FCR (= source)
- possible geographical locations of an imbalance (= sink)
- power network in the synchronous area that connects sources and possible sinks

Thus, a redistribution of FCR between two TSO does not result in a physical flow between these TSO, but in general to different flows with respect to the differences to the “base case”. Therefore all TSO are more or less affected in case of a redistribution of FCR. The Reserve Receiving and Reserve

Connecting TSO have to check if the power flows resulting from redistribution significantly impact the TRM of all involved TSO. In that case, an exchange of FCR is only possible, if the TRM of affected TSO are adjusted accordingly.

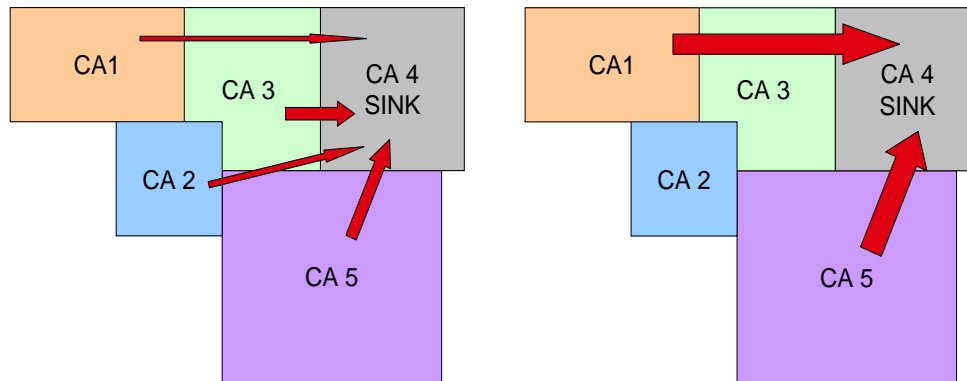

Figure 4: Examples for shift of power flows after redistribution of FCR with external sink

The redistribution of FCR should avoid concentration so that an even distribution of FCR is still ensured in case of network splitting. Each TSO can increase its FCR volume for delivery to other TSOs by up to 100 MW or up to 30 % of its initial obligation whichever it is the larger of the two values..

4 Frequency Restoration Reserve and Replacement Reserve Requirements

4.1 Description and Technical Concept

4.1.1 General Concept

Frequency Containment Reserve (FCR) stops a drop or increase in the system frequency after instant imbalances between generation and demand. After the drop (increase) has been stopped Frequency Restoration Reserve (FRR) is activated and brings the system frequency back to the normal frequency range. As a result FRR frees up FCR to be able to cope with the next failure or imbalance. When a relevant extent of the FRR is used, Replacement Reserve (RR) is activated to free up FRR to cope with the next imbalance.

The FRR can be organised as central frequency control per synchronous area or – in large synchronous areas like RE CE on the basis of de-central load-frequency control in control blocks. The choice of organisation of FRR is performed per synchronous area.

A control block may be a co-operation of a group of TSOs each operating a control area.

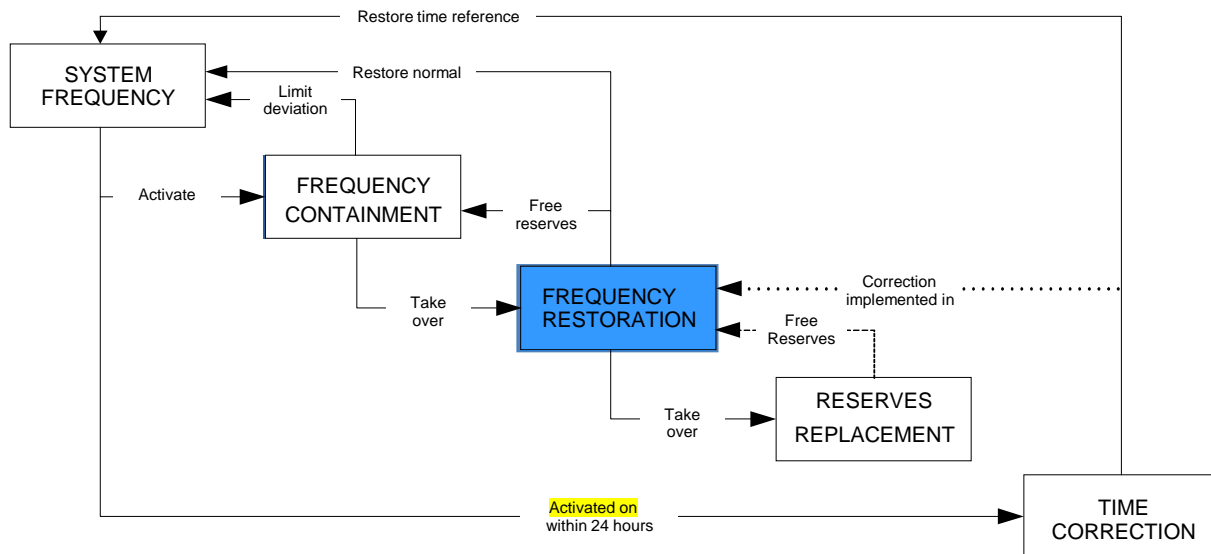

Figure 5: Technical control concept

FRR parameters:

- Dimensioning incident: The maximum expected power deviation between generation and load in a control area.
- Quality target: The quality of control every TSO must fulfil.
- ACE: Area Control Error.
- ACE^{OL} : Area Control Error open loop. It is defined as the sum of the ACE and all activated operational reserves (except FCR).
- Set point frequency: Frequency target value for FRR.
- Mode of activation of FRR: Implementation of activation of FRR depending on whether FRR are triggered manually by an operator or automatically by means of closed-loop control.
- Relieve time for FRR: Time period after which FRR, that have already been exhausted have to be relieved by RR.

Incidents, larger imbalances and normal volatility shall be fully covered by the activation of FRR. FRR can be freed up by activation of RR. The “normal volatility” is the uncertainty (normally caused by load and production noise) the TSO has to cope with during the time the market participants do not compensate their imbalance by themselves. This time window relates to the corresponding market design. The balance responsible parties are expected to react on the remaining imbalance on a market basis.

The TSO is responsible for fulfilling its control target and can decide which part of the capacity of FRR / RR is contracted as firm capacity and which part relies on the market and is hence subject to fluctuations.

4.2 Target and Performance Indicators

4.2.1 Target

The TSO's common and individual goal and obligation is to reach a common target. The amounts of FRR and RR needed for this are determined in the TSO's reserve dimensioning process, which shall

ensure that the common target can be fulfilled. The fulfilment of the quality target (jointly or individually) can be measured by performance indicators.

One general target for the individual FRR dimensioning is the availability of sufficient reserves to cope with the dimensioning incident. FRR shall be sufficient to replace the activated FCR within the time to restore frequency after the dimensioning incident (see section 3.3.1).

In addition a common quality target can be defined for “normal operation”. As a recommended quality target for a synchronous area the percentage of 15-minutes time⁴ units outside a given frequency band is measured. A target value is defined per synchronous area against which this number is evaluated (see section 3.3.2).

This quality target is valid for the control activities of the control area using a combination of FRR and RR.

For FRR and RR an additional target can be defined: the TSO shall not induce systematically an imbalance in the system resulting in a systematic system frequency distortion; the ACE shall be an appropriate measure for this distortion.

The solution to the hour shift ramping problem lies in the market re-design and not in the re-dimensioning of FRR or of RR.

4.2.2 Dimensioning Incident

In a synchronous area without any congestion FRR could be theoretically shared by all parties. In reality the FRR dimension and distribution are constrained by congestions inside the synchronous areas.

A TSO shall ensure it has access to sufficient reserves to cope with incidents occurring within its control area according to the rules of the synchronous area. The dimensioning incident is defined as the largest expected N-1 failure of generation, load or HVDC-interconnector.

The dimensioning incident determines the minimum required volume of FRR to cope with instantaneous failures within the control area.

As a performance indicator a monitoring of the system frequency behaviour after imbalances shall be in place within each synchronous area. After imbalances the system frequency must be restored to the band defined by the tolerance range for FCR activation within the time to restore frequency. The monitoring will be based on a performance indicator measuring the exceeding of a certain threshold. The threshold is defined on the level of synchronous areas.

TSOs are allowed to perform cross-border exchange of reserves with other TSOs or to share reserves in order to cope with the dimensioning incident under the conditions defined in the section 2.4. In this case congestions and the respective probability of being short of FRR due to FRR exchange limitations have to be taken into account. This issue has to be addressed within the reserve dimensioning.

In case of reserve sharing the final responsibility to cope with the dimensioning incident remains with the TSO affected by the incident. In case of insufficient operational reserves the TSO has to take appropriate measures to balance its own demand (for example, emergency load or generation reduction according to the type of imbalance).

In line with the 5 pillars approach the follow up of the fulfilment of this target has to be addressed in the compliance monitoring. In order to judge the fulfilment the following information is needed: the size of

⁴ 15 minutes refer to the time to restore the system frequency. This value can vary between synchronous areas.

dimensioning incident and how it is covered. This information can be shared ex ante after the occurrence of the incident.

4.2.3 Monitoring the Quality Target

4.2.3.1 Frequency as Unique Performance Indicator

As introduced in section 3.2 as a general quality target for a synchronous area the percentage of 15-minutes time units outside a given frequency band is measured. The 15-minute time frame is taken as the relevant time unit since it relates to the reaction time of FRR.

During an observation period, the number of 15-minute time frames, where the average system frequency deviation is outside a given threshold f_{THRS} , is counted. The percentage value (rate) $r(f_{THRS})$ is calculated by dividing this count by the total number of 15-minute time frames in the observation period. The observation period is typically 1 year.

As an ENTSO-E wide, unique performance indicator it is proposed to take a unique limit value for the percentage value (rate) $r(f_{THRS})$, but different values for the allowed frequency range f_{THRS} per Synchronous Area. The choice of these limit values is performed per synchronous area separately.

4.2.3.2 ACE as De-Central Performance Indicator

In large synchronous areas like RGCE, a de-central load-frequency-control of control blocks is applied. To satisfy the desired overall system frequency quality in this case the ACE of the individual control blocks must to be kept within defined limits on a continuous basis.

The FRR performance indicator in case of a de-centralised approach is based on the Area Control Error (ACE_i) of the control block i . The 15 minute time frame is taken as the relevant time unit since it relates to the reaction time of FRR.

The performance of de-centralised load-frequency control is measured by the combination of two indicators – an indicator measuring the compliance with the principle on non-intervention and another indicator measuring the severity of ACE deviation (area imbalances contributing to a frequency deviation increase are more severe than imbalances contributing to mitigation). The observation period is typically 1 year. This methodology serves as an indicator.

Indicator measuring the compliance with the non-intervention.

During the observation period, the number of 15-minute time frames, when the average ACE_i is outside the given threshold ACE_{THRS} , is counted. The percentage value (rate) $r(ACE_{THRS})$ is calculated dividing this count by the total number of 15-minute time frames in the observation period. The observation period is typically 1 year. This methodology serves as an indicator.

Using these metrics is in compliance with required control policies and the principle of non-intervention, in which each control block should compensate its ACE (its domestic imbalance) to acceptable limits. It also reflects the fact that the prescribed obligatory PI controller for load- frequency control reacts only to ACE and therefore its performance should be evaluated by appropriate metrics over ACE.

Based on overall system frequency quality requirements, individual ACE thresholds $ACE(f_{THRS})$ per control blocks can be calculated. Maximum relative time when those limits are exceeded remains constant among all control blocks and equals the value $r(f_{THRS})$.

The frequency threshold f_{THRS} for a whole synchronous area with a K-factor K_T is translated and decomposed in to the individual ACE_{THRS} thresholds for one control block with K-factor of K_i by this formula:

$$ACE_{\text{THRS}} = f_{\text{THRS}} \sqrt{K_T K_i}$$

Indicator of ACE deviation severity

During the observation period the sum of average ACEs in 15 minutes periods is counted separately when the area imbalances contribute to mitigation of frequency deviation and when imbalances contribute to frequency deviation increase. The ratio greater than 1 of the two previous values shows that the area tends to stabilise the system frequency while ratio lower than 1 shows that the area tends to worsen the frequency. The indicator of severity will complete the conclusions that come from the observation of the previous indicator.

4.3 Methodologies for Reserve Dimensioning

In general the dimensioning of reserves, in particular the dimensioning of FRR and RR in the context of this document is a trade-off between the available reserves, the costs related to the procurement of these. In any case the reserves need to be sufficient to fulfil the quality target and the dimensioning incident.

The reserve dimensioning of the individual TSO has to take into account the targets and performance indicators defined in section 2.1. According to the 5-pillar-approach there is no direct link to calculate the reserve needed from these targets and performance indicators. But there are state-of-the-art methodologies that can support the choice of the right level of reserves.

An overview, especially for the well accepted statistical and stimulatory approaches for Reserve Dimensioning, shall be given in the following sections. Section 3.3 will describe possible analyses of the control block's behaviour. The use of the following methodologies by the TSOs is recommended but not mandatory.

4.3.1 Statistical Methodology for Reserve Dimensioning

Within the statistical methodology probability density functions (PDF) of different system characteristics are modelled in order to define the need for FRR and RR for each activation direction. Although in general the determining factors are comparable across synchronous areas and across control blocks, it largely depends on the system itself which characteristic is to be judged as relevant or irrelevant. Hence each TSO has to choose the relevant characteristics for Reserve Dimensioning in its system.

Due to the fact that RR can be substituted by FRR, but not vice versa the statistical methodology for the dimensioning of FRR and RR can be apportioned into a two-step approach. In the first step the overall need for reserves (full value for the FRR / RR being FRR and RR as a sum) is determined. In the second step from that the need for fast and flexible reserves (i.e. FRR) is determined. The difference, the remaining need for reserves that does not need to be covered by FRR can be covered by RR.

Whereas for the dimensioning of RR in general the long term market forecast error is predominantly relevant, the need for FRR and hence its dimensioning is influenced, amongst others, by the following system characteristics:

- Short term forecast errors
- Unit outages
- Load noise
- Steps of the exchange programs

- Activation delay of RR

Renewable Energy Sources (RES) can affect both the need for FRR and RR, but the above mentioned characteristics can already include their effects.

In order to perform the dimensioning PDF for the relevant system characteristics are needed. Usually the PDF are extracted on the basis of observations from the past (e.g. for the last 12 months). If the characteristic's occurrence is too seldom and not systematic (like for unit outages) the PDF has to be created theoretically.

The overall probability density function of the system (relevant for FRR and RR or only FRR) is calculated by a mathematical combination of each of the single PDFs (convolution). From the resulting total probability density function the probability of having a certain power deficit in the system can be derived for each level of reserve procurement. Reserving this consideration the volume of the reserve needed can be chosen by defining a deficit probability, which is sufficient to fulfil the quality target.

4.3.1.1 Relevant Input Data

To estimate the market forecast errors (short term and long term as a sum) for reserve dimensioning the open-loop ACE (ACE^{OL}) is likely to be used⁵. Historical values of open loop ACE can be obtained by summing up the control block's ACE and all activated reserves:

$$ACE^{OL} = ACE + \text{all activated reserves}$$

Open loop ACE for dimensioning is constructed from several components:

$$\overrightarrow{ACE_{OL}} = \overrightarrow{ACE_{OL1}} + \overrightarrow{ACE_{OL2}} + \overrightarrow{ACE_{OL3}} + \dots$$

It is each TSO's decision what components are reflecting the control block's behaviour the best and hence have to be taken into account in the dimensioning or have to be removed from the database.

Typical components of the ACE^{OL} are:

$\overrightarrow{ACE_{OL1}}$ representing fast load noise

$\overrightarrow{ACE_{OL2}}$ representing slow load noise and short term market forecast errors

$\overrightarrow{ACE_{OL3}}$ representing long term market forecast errors

$\overrightarrow{ACE_{OL4}}$ representing unit outages

$\overrightarrow{ACE_{OL5}}$ representing fast and slow RES effects in case when RES influence is not included in $\overrightarrow{ACE_{OL1}}$, $\overrightarrow{ACE_{OL2}}$ components.

For each of these components a time resolution needs to be chosen. For most of the components a quarterly hour time resolution might be sufficient, however e.g. for the fast load noise and the short term market forecast errors a smaller time resolution might be needed in order to reflect the relevant characteristics.

After the convolution of all of the relevant PDFs of these data the overall PDF of power imbalances is known. It can be used to calculate the probability of having a certain power deficit in the system for the sum of both kinds of reserves FRR and RR.

⁵ Please note that in some market arrangements, e.g. centrally dispatched pool based markets, it is not possible to calculate easily open loop ACE as in these markets balancing actions are taken by TSOs in the framework of the same mechanism as redispatching actions and thus they are difficult to differentiate ex post.

The convolution of the PDFs relevant for fast and flexible reserve, the volatile part is only a part of ACE^{OL} , is used to calculate the need for FRR.

Choosing an ultimate value for the deficit probability in combination with the overall PDF gives the full value for the FRR / RR needed in the system. The need for Reserves should in this case be determined for each activation direction separately, thus the deficit probability needs to be attributed accordingly to the activation directions. According to the market possibilities the TSO decides about the “sourcing”, i.e. which part of the maximum value for the FRR / RR is reserved as “firm capacity” and which part can with an acceptable security be delivered by market parties. A TSO with no possibility to activate reserves from the market may have to contract the full value for the FRR / RR as “firm capacity”.

4.3.2 Simulation Methodology for Reserve Dimensioning

The statistical methodology models each time unit independently (i.e. non-sequential). It does not allow an analysis of the results of a course of events. This limitation can be overcome by the simulation methodology.

With this methodology the dynamic reaction of the whole system can be analysed. The basis is a pre-defined set of events. Typically these events are designed on the basis of experiences from the past. New probable phenomena not observed in the history can be also simulated.

The results of the simulation give the ACE of the system, which can be analysed with regards to the performance indicator. Thus quality target and reference incident reaction can be evaluated from simulation.

Typically during simulation a probable time series of open-loop ACE (or system frequency deviations in smaller system) is generated and activations/deactivations of operational reserves simulated.

Simulation model can be used for simulation of one run throughout investigated period or for a more complex Monte Carlo simulation. The advantage of Monte Carlo simulations is its ability to investigate a broad range of possible situations in a power network.

Ideally at least a whole year period is simulated, however to reduce computation time for Monte Carlo simulation representative shorter periods (typically months) could be used.

If Monte Carlo simulations are performed, it is recommended not only to evaluate system behaviour from by averaging all simulation run but also to choose few representative realisations for evaluation purposes, because averaging leads to some sort of result blurring. A pre-defined worst case is regarded as recommended security approach. Thus simulations results falling around 90 % quintile should be used for dimensioning operational reserves.

4.3.3 Statistical Analysis of Control Block Imbalances

In order to assess the adequacy of the amount of operational reserves the behaviour of each control block shall be analysed by the responsible TSO.

In this respect the ACE^{OL} representing the overall sum of imbalances within a control block is of special significance. ACE^{OL} is related to the overall need of reserves (FRR and RR) of a control block. The following rule applies in general: the higher the ACE^{OL} of a control block - the higher is the need for operational reserves.

Additionally the ACE^{OL} and its derivative $ACE^{OL'}$ – defined as the change of the ACE^{OL} from the previous time stamp – can be analysed. In relation to the ACE these two parameters give insight into the intrinsic behaviour of the analysed TSO system.

4.3.3.1 Analysis of Open-Loop ACE

When plotting ACE against ACE^{OL} in its quarterly hour dependency the following distribution is assumed to be typical.

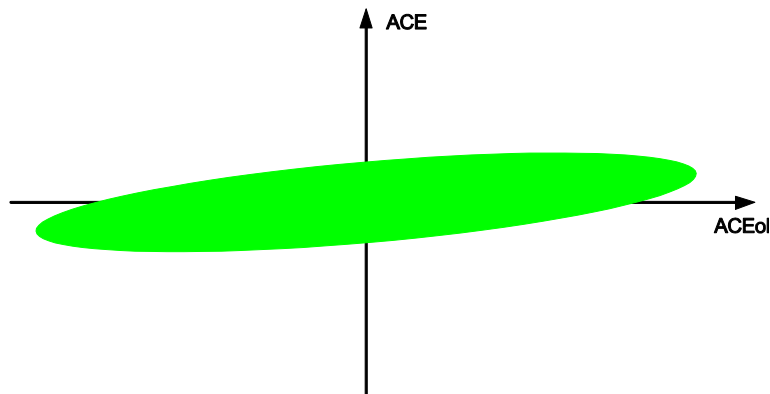

Figure 6: Typical point distribution

One can observe an equal distribution of ACE and ACE^{OL} to positive and negative values. Each of their probabilities abates with size and nearly follows a Gaussian distribution, defined by its variance σ and its mean value μ . The points are concentrated near the x- and the y-axis ($\mu = 0$). While assuming no interrelation between the ACE and ACE^{OL} being independently distributed according to a Gaussian distribution no patterns are recognizable (i.e. no statistical dependency). In this diagram the x-axis represents the “influence of the market” whereas the y-axis represents the result of the TSO control activities.

If the operational reserves available to the TSO are smaller than the highest observed ACE^{OL} the pattern as depicted in the following diagram is to be expected. It can be seen as a piecewise defined function. The flanks show saturation of reserve capacity.

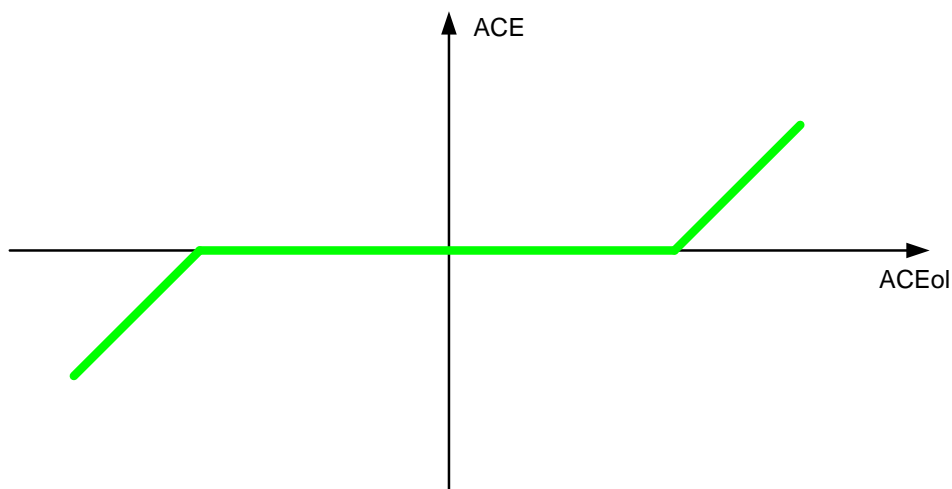

Figure 7: Saturation of reserves with instantaneous control

4.3.3.2 Analysis of the Fast Changing and Unpredictable Part of the Open-Loop ACE

The derivative of the ACE^{OL} being $ACE^{OL'}$ (defined as $ACEol'(t) = ACEol(t) - ACEol(t-1)$) can be seen as a proxy for the fast changing and unpredictable part of the ACE^{OL} and can be used to estimate the need for flexible reserves (e.g. FRR). The assumption is taken that the predictable and slow part of the ACE^{OL} can be outbalanced by slow reserves (e.g. RR), hence the remaining part has to be outbalanced by FRR.

A realistic point distribution is depicted in the following diagram. A linear relationship between $ACE^{OL'}$ and ACE ($ACE \sim k * ACE^{OL'}$) due to the “reactive” control (i.e. reaction of the control on an ACE different to zero) is recognizable. The steepness k is a measure for the overall control speed of the system.

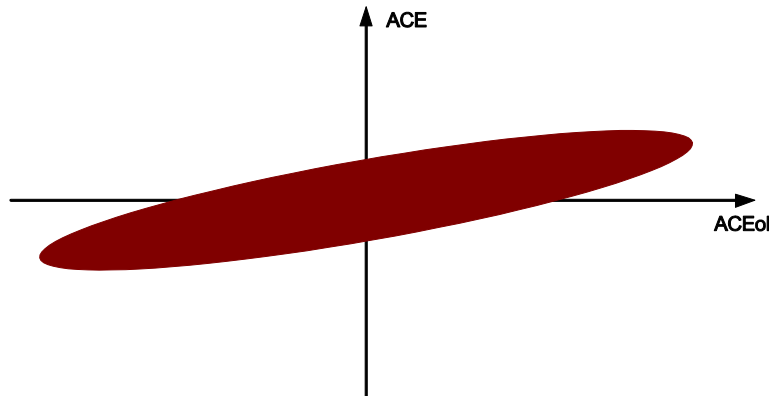

Figure 8: Realistic distribution

If the control speed was extremely fast the following pattern would be observed.

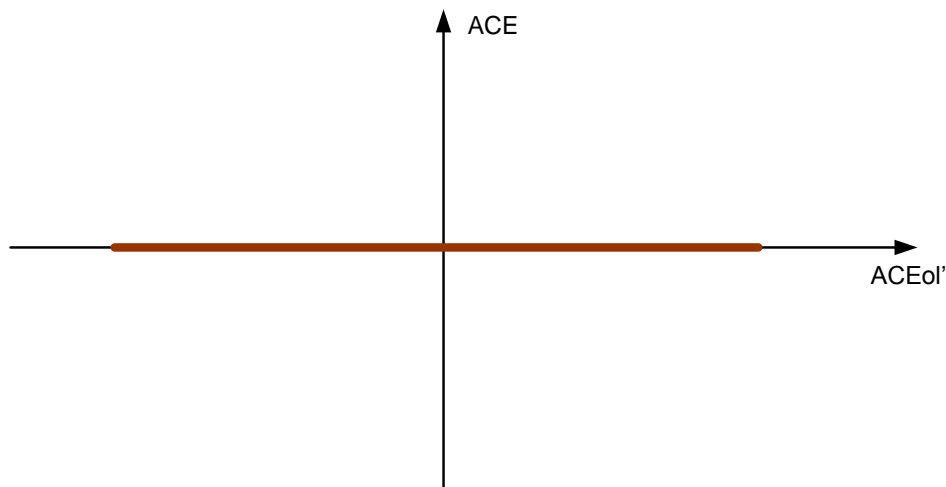

Figure 9: Fast control

If the control speed was limited and lower than the highest observed differentials of the ACE^{OL} it would be only possible to outbalance the differential $ACE^{OL'}$ within the same quarter of an hour up to a certain speed. If this speed is reached the remaining change goes directly in the ACE (visible as flanks in figure 9).

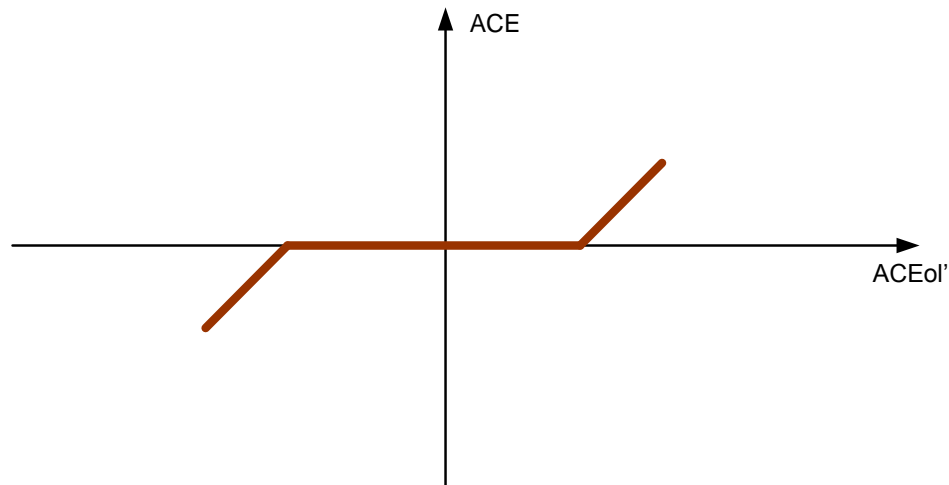

Figure 10: Limited speed of control

In the real world however, due to the reactive nature of the control loop and the limited speed of control a certain part of the ACE always stays imbalanced as depicted in the following diagram.

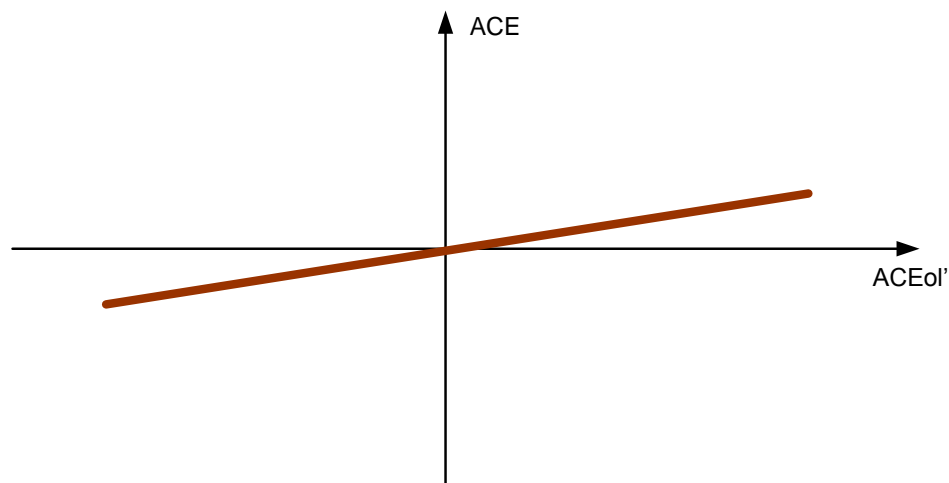

Figure 11: Normal control

4.4 Exchange, Sharing and Distribution of Reserves

4.4.1 Cross-Border Exchange of Reserves

In some synchronous areas FRR and RR requirements are calculated per control block and provided by the reserve providers located within the control block. Economic savings could result from the allocation and the use of the operational reserves on a broader basis than the own control block, enabling to benefit from the most economic reserve providing units located outside the control block.

It is necessary to design minimal requirements for cross-border exchanges of reserves in order to maintain the security standards for system operation.

Cross border exchanges of reserves refer to agreements among TSOs (control blocks) on guaranteed, prior to the market gate closure, control power capacity and consequent control energy delivery. In addition to that TSOs can use cross border control energy delivery which is not necessarily associated with guaranteed control power capacity.

For cross-border exchange of reserve and control energy the following basic principles have to be taken into account:

- The development of cross-border exchanges must not generate additional congestions and unexpected loop flows.
- The roles and responsibilities of the TSOs have to be defined and agreed accordingly.

The AhT OR recommends establishing a notification procedure on agreements of exchange of reserve and control energy aiming at verifying that these basic principles are followed.

4.4.2 Sharing of Reserves

Reserve sharing is a TSO-TSO agreement that allows TSOs to share part of their reserves between each other. The main difference between “sharing” and “cross-border exchange” is that cross-border exchanged reserves are exclusively available to one TSO, while shared reserves are available to more than one TSO.

The AhT OR recommends to establish a notification procedure of reserve sharing agreements aiming at verifying that reserve sharing do not jeopardize the system security and that the network is able to transmit the flows resulting from the activation of these shared reserves.

One criterion for FRR dimensioning is that each TSO must be able to cope with its dimensioning incident (see section 3.3). This individual dimensioning approach results in a total volume of FRR that is considerably larger than the required FRR in case of a common dimensioning approach for a group of TSOs.

In order to enhance overall efficiency of the system, reserve sharing allows TSOs, to share part of their FRR to meet individual FRR dimensioning incident dimensioning targets or to increase overall system security. It is acknowledged that sharing of reserves introduces a risk associated with the transmission capacity which should be evaluated by the affected TSO. The final responsibility to cope with the dimensioning incident however always remains with the affected TSO.

The basic volume of FRR should at all times be exclusively available to a TSO and must be located geographically within his control area (see section 4.4.3: distribution of reserves). The basic volume of FRR cannot be shared amongst TSOs. Reserve sharing is only possible for FRR additional to the basic volume of FRR.

Interconnection congestions shall be taken into account, since they have impact on the actual availability of shared reserves.

4.4.3 Distribution of Reserves

The distribution of reserves is independent from the question of cross-border exchange of reserves or reserve sharing. It gives rules for the distribution of reserves inside a synchronous area.

With regard to FRR the limitation of situations with insufficient reserve is relevant. In order to keep sufficient FRR in any case and at any time it is proposed to maintain a basic volume of FRR inside the control area.

As a general principle the activation and reaction time of the fastest RR product in combination with the predictability and the rate of change of the ACE^{OL} are the determining factors for this basic FRR volume. The part of the ACE^{OL} which can not be balanced by RR consequently always needs to be balanced by FRR.

Under the assumption that the RR of the next $\frac{1}{4}$ h is always activated on the FRR activation of the current $\frac{1}{4}$ h it turns out that the derivative of the ACE^{OL} represents the FRR that has to be available in a

control area to cope with the volatility. The basic FRR volume is calculated per control area on the basis of the probability distribution function of the derivative of ACE^{OL} .

As an initial proposal a saturation probability of 10 % (5 % for positive and negative share) is suggested as commonly accepted to determine the level of the basic FRR volume, which has to be available in the TSO control area. With this each TSO will have sufficient FRR within its control area to cope with the derivative of ACE^{OL} for 90 % of time. This basic volume has to be always available in the system operation (i.e. a “generalisation” of the “square root formula” from the UCTE Operation Handbook).

Further experience is needed to assess the robustness of this criterion on the several years period and to confirm the threshold of percentage.

A. Mapping Processes to Products

| Sync. Area | Process | Product | Activation | Local / Central | Dynamic / Static | Full deviation | Full activation |
|------------|---------|-------------------------------------------|------------|-----------------|------------------|----------------|-----------------|
| BALTIC | FCR | Primary Reserve | A | L | D | ±200 mHz | 30 s |
| Cyprus | | Primary Reserve | A | L | D | ±100 mHz | 20 s |
| Iceland | | Primary Control Reserve | A | L | D | variable | variable |
| Ireland | | Primary operating reserve | A | L | D / S | >±200 mHz | 5 s |
| Ireland | | Secondary operating reserve | A | L | D / S | ±200 mHz | 15 s |
| NORDIC | | FNR (FCR N) | A | L | D | ±100 mHz | 120 s -180 s |
| NORDIC | | FDR (FCR D) | A | L | D | ±500 mHz | 30 s |
| RG CE | | Primary Control Reserve | A | L | D | ±200 mHz | 30 s |
| UK | | Frequency response dynamic | A | L | D | variable | 10 s / 30 s |
| UK | | Frequency response static | A | L | S | variable | variable |
| BALTIC | FRR | Secondary emergency reserve | M | C | S | n.a. | 15 minutes |
| Cyprus | | Secondary Control Reserve | A/M | L / C | D / S | n.a. | 5 minutes |
| Iceland | | Regulating power | M | C | S | n.a. | 10 minutes |
| Ireland | | Tertiary operational reserve 1 | A/M | L / C | D / S | n.a. | 90 s |
| Ireland | | Tertiary operational reserve 2 | M | C | S | n.a. | 5 minutes |
| Ireland | | Replacement reserves | M | C | S | n.a. | 20 minutes |
| NORDIC | | Regulating power | M | C | S | n.a. | 15 minutes |
| RG CE | | Secondary Control Reserve | A | C | D | n.a. | 15 minutes |
| RG CE | | Direct activated Tertiary Control Reserve | M | C | S | n.a. | 15 minutes |
| UK | | Various Products | M | n.a. | D / S | n.a. | variable |
| BALTIC | RR | Tertiary (cold) reserve | M | C | S | n.a. | 12 h |
| Cyprus | | Replacement reserves | M | C | S | n.a. | 20 minutes |
| Iceland | | Regulating power | M | C | S | n.a. | 10 minutes |
| Ireland | | Replacement reserves | M | C | S | n.a. | 20 minutes |

| | | | | | | |
|---------------|---------------------------------------------------|---|------|-------|------|------------------------------|
| NORDIC | Regulating power | M | C | S | n.a. | 15 minutes |
| RG CE | Schedule activated Tertiary Control Reserve | M | C | S | n.a. | individual |
| RG CE | Direct activated Tertiary Control Reserve | M | C | S | n.a. | individual |
| UK | Various Products (mainly STOR) | M | n.a. | D / S | n.a. | from 20 minutes to 4 h |

Table 3: Mapping Processes to Products; manual (M) or automatic (A) activation; activated centrally by the TSO (can be manual or automatic) (C) or activation directly at a local reserve provider (L)

B. Frequency Distributions in Europe

HELLO WORLD!

C. Probabilistic calculations on Frequency Containment Reserve dimensioning and target performance

Within the scope of the AhT OR probabilistic calculations have been performed in order to propose possible methodologies for dimensioning of the reference incident and for setting a number of minutes per year in which the average value of the frequency of a synchronous area is outside the standard frequency deviation band.

These calculations are explained in this Annex, which includes examples of the results they deliver for certain synchronous areas.

C.1. DIMENSIONING OF THE REFERENCE INCIDENT

The reference incident is defined as the maximum expected instantaneous power deviation between generation and demand in the synchronous area for which the dynamic behaviour of the system is designed. Its value is expressed in MW.

The reference incident should be an event rare enough to assure that the frequency of the synchronous area is maintained during the occurrence and recovery of the incident within the design limits with great confidence. The synchronous area must be designed in such a way that after the occurrence of an unbalance smaller or equal to the reference incident the system is returned to a stable state without the need for load-shedding. The design hypothesis that should be applied should be based upon unfavourable parameters which provide a margin of safety in estimated values. Consequently, it is probable that even more serious incidents could be accommodated in practice without the need for load shedding.

Frequency Containment Reserves (FCR) should be sized equal or larger than the reference incident to assure that for an imbalance disturbance smaller or equal to the reference incident the frequency will be stabilized by the deployment of these fast acting reserves. In smaller systems, a certain amount of load shedding may be used to stabilize the system after the occurrence of the reference incident due to technical or economic reasons as the speed of the generation units is not fast enough to overcome the frequency fall due to the small inertia of the system.

The reference incident should be sized taking into account at least the loss of the biggest power generation/consumption unit or the loss of a line section, bus-bar or HVDC interconnector that may cause the biggest unbalance. In larger systems with many units there is a larger probability of an

additional loss of generation, consumption or in-feed before the system has recovered from a previous loss within the design window. A more detailed analysis has been performed for the Continental Europe system to estimate a reasonable size of reference incident to assure that incidents leading to an even greater imbalance are extremely rare, but within some boundaries since the different type of reserves must be procured according to the size of the reference incident with consequences on the overall efficiency of the system.

This analysis has been carried out with a probabilistic assessment making use of historic data to determine which is the largest generation/in-feed loss expected in a certain number of years. It is assumed that the largest imbalance occurs due to generation or HVDC interconnector tripping as imbalances due to loss of supply are much smaller than those linked to generation assuming that the system is in a normal state. Significant fluctuations of variable renewable resources occur on a wider time frame and are not taken into account in this analysis.

A generation scenario for a peak moment is modelled with the units larger than 200 MW. It is assumed that the units are operating at full capacity and that when a unit trips it loses its full power and does not reconnect to the network within the next 30⁶ minutes. The expected number of trips per year based on historic data is used for each unit considered in the scenario. It is assumed that the probability of tripping of a certain unit is constant in time and therefore a Poisson distribution is used to determine the probability that each unit has of tripping in a certain minute using the following formula:

$$p(\lambda) = 1 - e^{\frac{-\lambda}{525600}}$$

where p is the probability of tripping of the unit in a certain minute and λ is the number of trips per year of the unit. The number of trips per year must be divided by the number of minutes in a year (525600 for a non-leap year) as the probability to be calculated is the probability in each minute.

When a unit trips, it is assumed that the FCR recover the balance of the system in the same minute as the deployment time of FCR in the Continental Europe system is 30 seconds. The loss of generation is counteracted only with FCR so assuming that the system starts in perfect balance and FCR are fully available the use of FCR in the minute of the tripping of the unit is equal to the generation loss. The effect of the self-regulation of loads is in general not taken into account.

In the case of synchronous areas like RG CE in which there are large power plants with several generating units or that are connected to the network in the same node or to the same bus-bar, in the case of bus-bar or of full substation failure all of the generating units connected to the bus-bar or to the substation would trip at the same time. Furthermore, within a power plant there might be some modes of common failure of more than one generating unit due to extreme weather conditions, cooling problems etc. The probabilities of these events are taken into account as well.

The average number of trips per year of common simultaneous multiple failures have been calculated with available data from France in the last 10 years and from Spain in the last 6 years and extrapolated to the whole synchronous area. Each multiple failure has been modelled as a single failure of the sum of the generation of the generating units that would trip simultaneously so the number of trips per year of these failures is significantly lower than the number of trips per year of single units. A large number of simulation steps is needed to assure that these events with very low probability also influence the results as close as possible as they do in real life.

The Monte Carlo simulation is time sequential since it is essential to model that the FCR used in one minute to counteract an imbalance in the previous minute will not be recovered and there is a probability for another unit to fail and trip before the FCR has been replaced by the Frequency

⁶ It is assumed that the reconnection time of the units that have tripped is greater than 30 minutes. It is based on a 15 minutes delay of the complete deployment of FRR plus the next 15 min if the FRR is not available when the unit tripped.

Restoration Reserves (FRR). The effect of the FRR in the FCR is modelled considering that FRR deployment is equivalent to the response of a first order linear system with a time constant of 5 minutes⁷.

In the case of error correction the response of a first order lineal system would be:

$$y(t) = A * e^{-\frac{t}{\tau}}$$

with A being the initial error and τ the time constant. In the case of the Monte Carlo simulations A depends on the initial ACE of the control area that has an unbalance which is generally unknown. However, the relationship between the error at time t and the error at time $t+1$ is easy to calculate:

$$\frac{y(t+1)}{y(t)} = \frac{A * e^{-\frac{-(t+1)}{\tau}}}{A * e^{-\frac{-t}{\tau}}} = e^{-\frac{1}{\tau}} = e^{-\frac{1}{5}} = 0.8187$$

With a time constant for the deployment of FRR τ of 5 minutes the relationship between the ACE of the area in which the generation trip occurred at time $t+1$ is 0.8187 of the ACE at time t if no other trip occurs in the same area assuming that this trip is the only unbalance that has occurred in the synchronous area.

This type of response is modelled in the Monte Carlo simulation multiplying the FCR used in a minute by 0.8187 to calculate the FCR used in the next due to previous trips. If new units trip in the following minute their power is added to the multiplication (Figure 12).

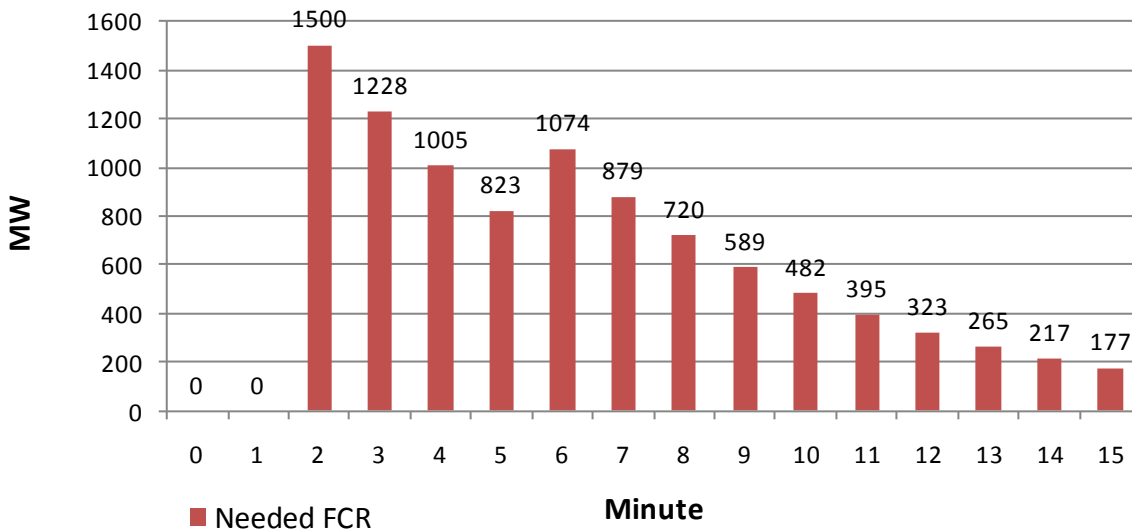

Figure 12: Example of used FCR in the Monte Carlo simulation if a unit of 1500 MW trips in minute 2 and a unit of 400 MW trips in minute 6

In order to simulate a large enough number of minutes the Monte Carlo simulation is run for 10^8 minutes or about 190 years. The probability density function of the needed FCR due to generation tripping is deducted from the number of minutes in the simulation where the needed FCR was of a certain amount. The minutes are classified using 10 MW intervals. The results are shown in Figure 13.

⁷. The time constant of 5 minutes is derived from the UCTE Operational Handbook Policy 1, which states that the secondary reserves must be deployed within 15 minutes to recover the frequency and the primary reserve. A first order lineal system is generally considered to have reached the step response target when it reaches 95 % of its value, which occurs at a time t 3 times larger than the time constant.

From the results of the simulation it can be concluded that if in a large interconnected system only the loss of the biggest unit or in-feed is considered as the reference incident and the FCR are dimensioned according to this reference incident the risk of needing more FCR than available and therefore the risk of triggering of under-frequency load-shedding relays may be too high. In the Monte Carlo simulations for the Continental Europe system this risk would be of 0.00001554 or 8.17 times per year.

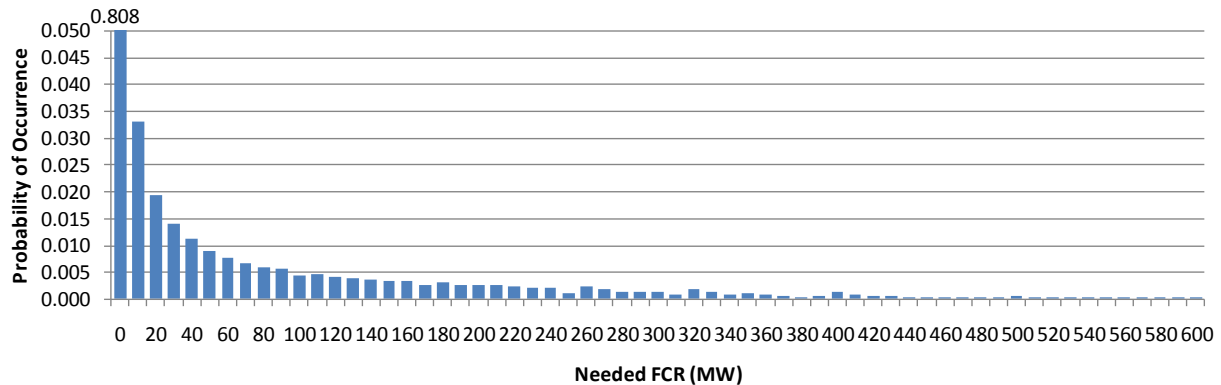

Figure 13: Probability distribution of the needed FCR in each minute in RG CE due to generation trips from 0 to 600 MW.

The maximum needed FCR for the 10^8 minutes was of 2910 MW. It must be noted that in the simulation it has been assumed that the generation trips occur independently from each other except for generating units located in the same plant or that are connected to the network in the same node whereas a number of circumstances (large disturbances, extreme weather conditions, etc.) may occur leading to a simultaneous trip of several large units in a short period of time in a different location or connected to a different substation. The present reference incident defined for the Continental Europe system of the sum of the two largest units, an N-2 criterion, or 3000 MW seems as a reasonable reference incident, conservative enough to assure that larger unbalances will be rare, but within reason.

C.2. NUMBER OF MINUTES OUTSIDE THE STANDARD FREQUENCY BAND

C.2.1. Introduction

An analysis of the frequency behaviour of a synchronous system shows that large unbalances are not only caused by generation tripping. Other reasons for unbalances are changes in the demand, changes in the generation of renewable energy technologies and changes of production in the large generation units due to program changes from one programming period to the other. These last unbalances have become more frequent and more severe in the last years as markets evolve. In fact, in large systems, most large frequency deviations occur in the first 5 minutes before the hour change or in the first 5 minutes of the hour. In the Continental Europe system, in the year 2010 there were 6 times more minutes in which the average frequency deviation during the minute was higher than 75 mHz within the 5 minutes before and after the hour change than in the rest of the minutes. Since deviations around the change of the hour are much more frequent and severe, all these frequency deviations not associated with generation trips will be referred throughout the present document as *market induced unbalances*.

These market induced unbalances, not associated with unexpected trips of load or generation, cause a generation-load unbalance as well and are compensated by the deployment of some FCR leading to frequency deviations. Until the FRR take over the deployed FCR, some FCR will be already in use and therefore not ready to counteract the effects of a generation or load trip. The larger that these frequency deviations are and the more time it takes to counteract them the more probable it is that a large generation or load unbalance incident occurs when some FCR are deployed due to market induced

unbalances leading to an event that will cause the frequency to surpass the established limits within the design of the system and possibly to under-frequency load-shedding.

The number and length of the frequency deviations must therefore be supervised and limited. For example, in the Nordic System, one of the frequency quality goals is that the frequency does not stay outside the ± 100 mHz band more than 6000 minutes per year. The minutes are counted as inside or outside the band by integrating the frequency value for the whole minute.

C.2.2. Probabilistic methodology to calculate the risk associated to frequency deviations due to causes others than generation tripping.

In order to quantify the risk of needing more than the contracted FCR by the combination at the same time of a frequency unbalance and a generation trip a probabilistic assessment can be performed. This probabilistic assessment will show the consequences of poor frequency quality by calculating the risk of using up all the FCR available by the combination of a frequency deviation prior to an unbalance due to a large generation trip. Such scenario will lead to the exhaustion of the FCR without stopping the frequency fall. The frequency will then be most likely stabilized by the activation of under-frequency load shedding relays and an unwanted loss of supply to some customers.

In the probability calculation it will be assumed that the frequency deviations due to changes in demand or renewable generation and the market induced unbalances are independent from the generation losses due to trips in the generation units. Both effects can be modelled by a probability density function of the needed FCR to counteract them. The probability density function of the needed FCR due to generation trips can be calculated with the method shown in the first section of the present document. An example for Continental Europe was shown in Figure 2.

The probability distribution function of the needed FCR due to market induced unbalances can be derived from the FCR deployment that is caused by a frequency deviation. It can be assumed that the deployment of FCR is lineal to the frequency deviation in a quasi-steady state after the dynamic effects of the unbalance have disappeared. For example, a frequency deviation of half the maximum quasi-steady state frequency deviation will lead to the deployment of half of the available FCR. With this assumption and a set of data regarding frequency deviations not associated with generation trips a set of data of the FCR needed due to market induced unbalances is derived and therefore also its probability distribution function.

As an example, the minute average frequency deviations for all of the minutes of the year 2010 for the Continental Europe system have been used. In order to discard the frequency deviations due to generation trips the 15 minutes after a generation loss larger than 1000 MW in 2010 have been discarded. Since in the Continental Europe system the theoretical available FCR at all times is 3000 MW and the quasi-steady state frequency deviation 200 mHz or 0.2 Hz the frequency deviations are multiplied by -15000 MW/Hz⁸. The distribution function of the need of FCR due to market induced frequency deviations is shown in Figure 14. This probability density function, contrary to the one for generation trips, has a positive and a negative side as market induced frequency deviations can occur both on the positive or the negative side.

⁸ The minus sign must be introduced as negative frequency deviations lead to positive need for FCR.

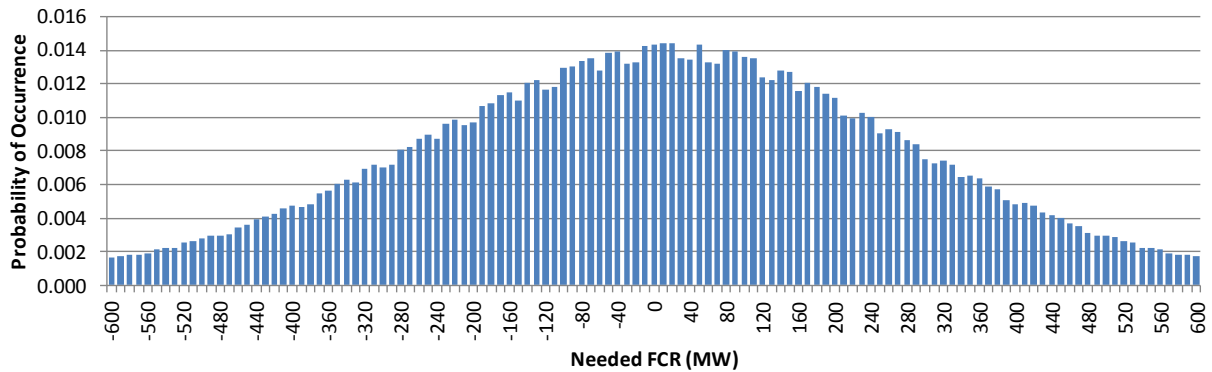

Figure 14: Probability distribution of the needed FCR due to market induced unbalances from -600 to 600 MW.

In order to calculate the risk of needing more FCR than it is available the distribution function of the total needed FCR is generated. Since the needed FCR is the sum of the needed FCR due to generation trips and the needed FCR due to market induced unbalances, the total needed FCR probability distribution function is obtained by means of the convolution of the both prior probability distribution functions. This function is shown for the example of Continental Europe in 2010 in Figure 15.

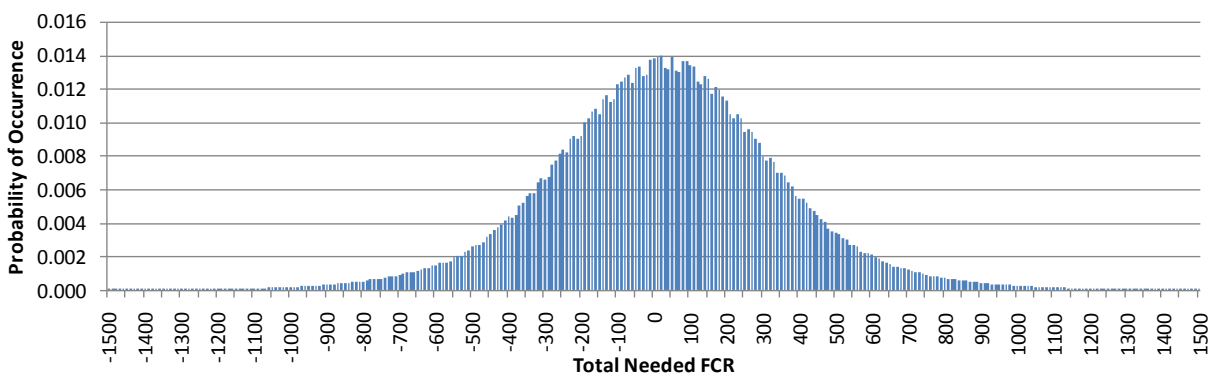

Figure 15: Probability distribution of the total FCR from -1500 to 1500 MW in RG CE.

Integrating the probability distribution of the total FCR from the available FCR to $+\infty$ the risk of needing more FCR than it is available can be obtained. In the case of Continental Europe for 2010 this integral equals 0.00000010 or once in 19.3 years.

This number shows the severity of the effect of the market induced unbalances. If the market induced unbalances did not occur the probability for the Continental Europe system to run out of FCR would be less than once in 190 years according to the calculations performed compared to once in 19.3 with the real frequency data.

C.2.3. Number of minutes outside the standard frequency deviation and risk of needing more FCR than available.

The number of minutes outside a standard frequency deviation band is a measure of the frequency quality. Assuming that the number of minutes outside the frequency deviation band due to generation trips remains constant in time and the probability distribution of the needed FCR due to market induced unbalances follow a certain modified t-Student function, the risk of needing more FCR than available can be generalized and calculated for a given number of minutes outside a standard frequency deviation band.

This modified t-Student function is the following distribution:

$$s(t) = f\left(\frac{t}{m}\right) * K$$

where $f(t)$ is a t-Student distribution, K is the constant that makes the integral of $s(t)$ equal to 1 and m is a multiplier related with the dispersion of the data as the t-Student functions always has a standard deviation of 1 which is not the case with real data:

$$f(t) = \frac{\Gamma\left(\frac{\nu+1}{2}\right)}{\sqrt{\nu\pi} \Gamma\left(\frac{\nu}{2}\right)} \left(1 + \frac{t^2}{\nu}\right)^{-\frac{\nu+1}{2}},$$

where ν is the number of degrees of liberty of the t-Student function and Γ is the Gamma function.

Since in the real data the tails of the distribution drop suddenly at around ± 125 mHz or 1875 MW the Student's t distribution has been also truncated outside the ± 1900 MW range to improve the fitting. The real frequency distribution function has only 5 minutes outside the ± 125 mHz band.

In the case of the Continental Europe system the probability distribution function of the needed FCR due to market induced unbalances has been fitted to a t-Student distribution with 10 degrees of liberty ($\nu = 10$) and a multiplier of 307 ($m=307$). The distribution fitting has been performed equalling the number of minutes outside the 75 mHz range in the real data discarding those that were caused by generation tripping of more than 1000 MW simultaneously and in the Student's t (Figure 16). The total number of minutes outside the 75 mHz range were 2361 out of which 132 were due to generation trips larger than 1000 MW and 2229 minutes due to market induced unbalances.

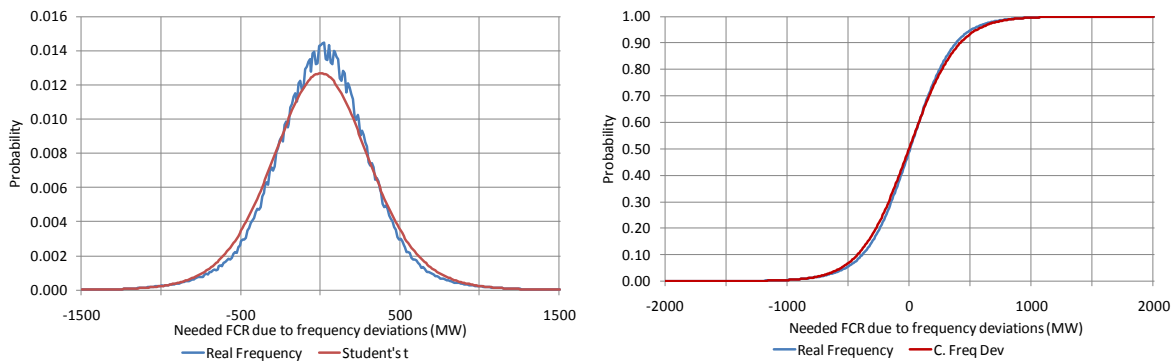

Figure 16: Probability distribution and cumulative distribution of the FCR needed due to the real frequency deviations in 2010 not associated with sudden generation trips and the Student's t distribution to which these values were adjusted.

The t-Student is then convoluted with the FCR needed due to generation trips and the integral from 3000 MW to $+\infty$ of the convolution is calculated and checked with the real risk of needing more FCR than is available. If the fitted t-Student data instead of the real data is used for the FCR due to market induced unbalances the probability of needing more than 3000 MW is of 0.00000011 or once in 17.9 years. This value is very similar to the probability of once in 19.3 years obtained with the real data (Figure 17). The number of minutes of the t-Student function outside the ± 100 mHz or ± 1500 MW range, 273 minutes, matches closely also the real value of 270 minutes.

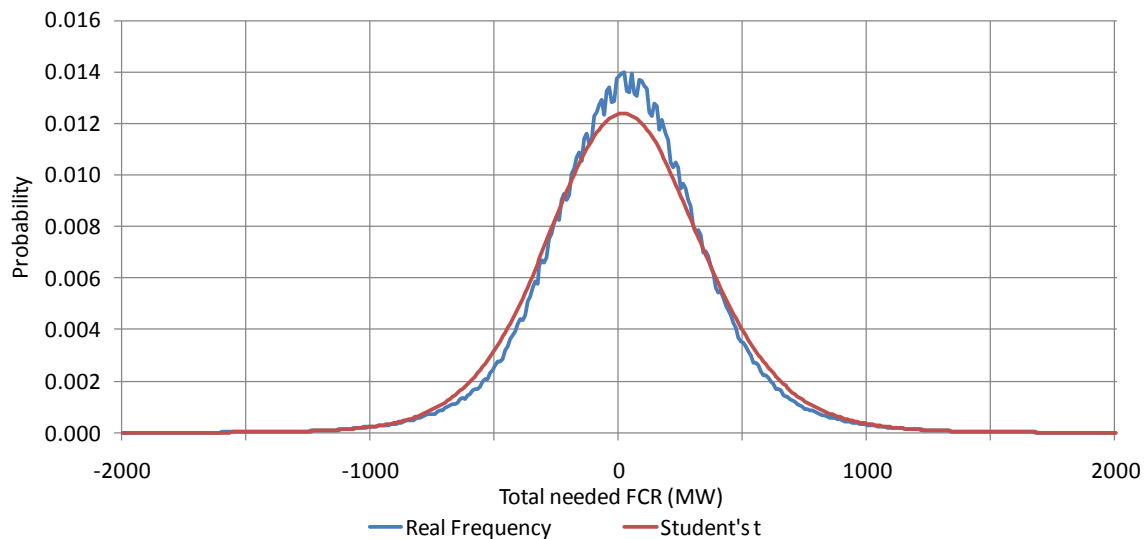

Figure 17: Distribution of probability of the FCR need due to the combination of frequency deviations and sudden generation trips using the real frequency deviations and the Student's t to which it was adjusted.

Assuming that the degrees of freedom of the t-Student distribution remain constant as the frequency quality varies, quantified by the number of minutes outside the 75 mHz, it can be calculated how the risk of needing more than the available FCR increases or decreases as a function of the frequency quality. It is also assumed that the number of minutes outside the 75 mHz band due to generation trips remains constant. In order to find the t-Student distribution that corresponds to a certain number of minutes outside the 75 mHz the parameter m is varied. These new distributions can show how the risk of needing more FCR than 3000 MW changes as the number of minutes outside 75 mHz increases or decreases.

If instead of 2360 minutes outside the 75 mHz range, there were 3000 minutes outside of the range it is considered that 2878 minutes are due to market induced unbalances (3000-132 minutes). In this case the parameter m of the t-Student distribution would be 321 instead of 307 and the probability of needing more than 3000 MW of FCR would increase to 1 in 15.66 years. An increase of 27 % in the number of minutes outside of the 75 mHz range increases the risk of needing more FCR than is available in 20 %.

Subsequently, using the same methodology a frequency quality leading to only 2000 minutes outside the 75 mHz range returns a parameter m of 298 and a risk of needing more than 3000 MW of FCR 1 in 19.44 years.

This same process can be used to obtain what would be the amount of FCR needed to maintain a desired risk for a given number of minutes outside the 75 mHz. If the registered frequency had 3000 minutes outside the 75 mHz band the FCR required to maintain a risk of needing more than the available FCR 1 in 19.3 years would be of 3040 MW. If the frequency quality kept degrading to 4000 minutes per year outside the 75 mHz band (parameter $m=340$) the risk would be of 1 in 13.4 years. The Continental Europe system would need 3070 MW of FCR to maintain the risk of needing more FCR than available in 1 in 19.3 years.

Looking at past years, the evolution of the risk of needing more than 3000 MW of FCR from the year 2002 until the year 2010 is represented in the following table:

| Year | Number of minutes outside +75 mHz | Student's T Multiplier m | Risk of needing more than 3000 MW of total FCR. Years between events. |
|------|-----------------------------------|----------------------------|-----------------------------------------------------------------------|
| 2002 | 581 | 240 | 32.5 |
| 2003 | 1325 | 274 | 23.5 |
| 2004 | 1455 | 282 | 22.5 |

| | | | |
|------|------|-----|------|
| 2005 | 1358 | 279 | 23.1 |
| 2006 | 2040 | 299 | 19.2 |
| 2007 | 1113 | 269 | 25.3 |
| 2008 | 1860 | 294 | 20.2 |
| 2009 | 2048 | 299 | 19.2 |
| 2010 | 2360 | 307 | 19.3 |
| 2011 | 1711 | 290 | 20.9 |

It can be observed how this risk has increased dramatically in 10 years. In the year 2002, with 581 minutes, and 2005, with 1358 minutes outside of the 75 mHz band, assuming the same units were online as today, the risk of running out of FCR was of 1 in 32.5 years and 1 in 23.1 years respectively.

Due to the sensitivity of the risk of needing more than 3000 MW to the amount of minutes outside the 75 mHz range an indicator or limit should be set and actions taken to assure that the security of the system is not jeopardized by the market induced frequency deviations.

C.2.4. Influence of unit size in the risk of needing more than the available FCR.

With the methodology described in paragraph 2.3 additional calculations have been performed to determine the influence of the size of the units in the system on the risk of needing more than the available FCR.

A new Monte Carlo simulation for RG CE has been carried out in which the units larger than 800 MW are substituted by 800 MW units. Additional units are modelled so that the amount of generation is equal in both scenarios. With a frequency quality similar to today's the risk of running out of available FCR decreases very significantly, to 1 in 480 years.

C.2.5. Influence of the real network power frequency characteristic in the risk of needing more than the available FCR for RG CE.

In the simulations described in the last sections of the document it was assumed that the only elements in the synchronous are that were frequency dependent were the FCR providers and that its provision of FCR was exactly what was contracted or compulsory. The self-regulation of loads was discarded. This assumption leads to a network power frequency characteristic of -15000 MW/Hz. In reality due to the self-regulation of loads and to further reaction of the generating units it has been established by analysing imbalances that the average network power frequency characteristic is of -26'434 MW/Hz. This average value includes 4055 MW/Hz of self-regulation of loads considering 1 %/Hz.

Based on a network power frequency characteristic of -26434 MW the simulations are performed as well calculating a new probability distribution of the used FCR due to market induced unbalances. When convoluted with the probability distribution of the used FCR due to generation trips a new probability distribution for the total needed FCR is obtained. The probability that the total needed FCR exceeds 3000 MW, the contracted FCR, increases dramatically to 33 times per year or once each 0.03 years. However, as the self-regulation of loads is included in the 26434 MW/Hz, this effect should be taken into account also when determining the size of the FCR available which would then increase in 811 MW ($4055 \text{ MW/Hz} \cdot 0.2 \text{ Hz}$) from 3000 to 3811 MW. The probability that the total needed FCR exceeds 3811 MW is of 1 each 20.5 years.

The results of this analysis show that there are very small differences between the use of the theoretical and the real network power frequency characteristic.

C.2.6. 2.6 Influence of the speed of deployment of FRR in the risk of needing more than the available FCR for RG CE.

In the simulations described in paragraphs from 1.1 to 2.5 it was assumed that the FRR replaced FCR as a first order linear system with a time constant of 5 minutes. The sensitivity of the results to the speed of deployment of FRR has been analysed performing the Monte Carlo simulations considering that the time constant of the linear system is also 2.5, 7.5, 10 and 15 minutes. The following figure shows the probability distributions of the used FCR due to generation loss considering different speeds of deployment of FRR.

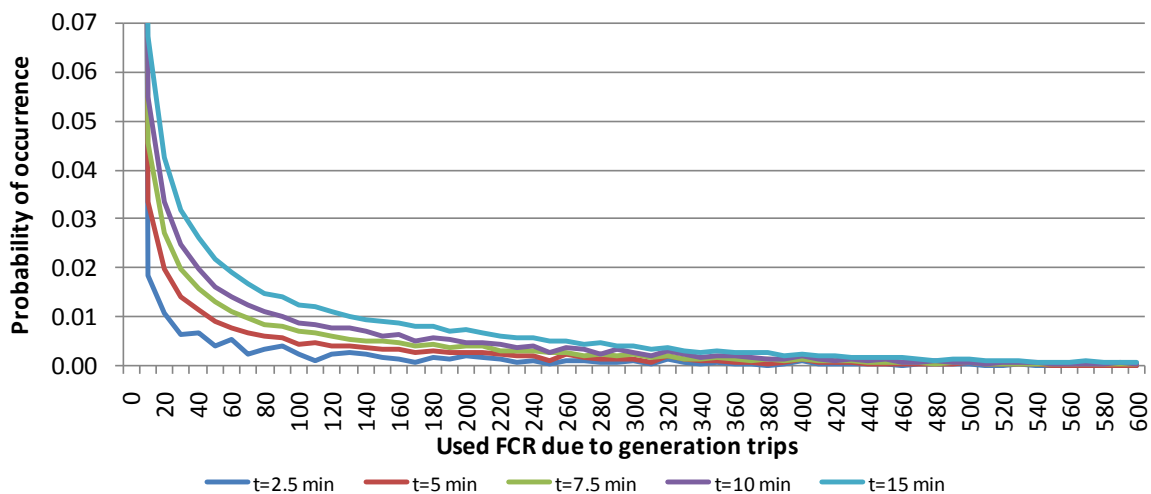

Figure 18: Probability distribution of the needed FCR in each minute in RG CE due to generation trips from 0 to 600 MW considering different time constants for the speed of deployment of FRR.

It can be observed in Figure 18 that the lower the time constant, the faster the speed of FRR deployment and therefore the lower the use of FCR due to generation trips. The following table shows the probability that the FCR is not used at all in any given minute, the maximum use of FCR in a minute due solely to generating unit's trips and the risk that the amount of total FCR needed due to both market induced unbalances and generation trips exceeds the available 3000 MW.

| τ (minutes) | Probability of 0 MW | Maximum Used FCR due to generation trips in 10^8 min (MW) | Risk of needing more than 3000 MW of total FCR Years between events |
|------------------|---------------------|-------------------------------------------------------------|---------------------------------------------------------------------|
| 2.5 | 0.897 | 2910 | 1 in 20.1 years |
| 5 | 0.807 | 2910 | 1 in 19.3 years |
| 7.5 | 0.728 | 3010 | 1 in 12.7 years |
| 10 | 0.652 | 3060 | 1 in 9.61 years |
| 15 | 0.524 | 3700 | 1 in 4.71 years |

Table 4: Deployment of FRR and risk of needing more than 3000 MW

Table 4 shows the importance of the speed of deployment of FRR in the risk of needing more than the available 3000 MW. In fact, if the time of deployment of FRR changes from 5 to 10 minutes the risk difference is more than doubled, from 1 in 19.3 years to 1 in 12.7 years.

C.2.7. Influence of the probability of deployment of FRR in the risk of needing more than the available FCR for RG CE.

In the simulations described in paragraphs from 1.1 to 2.5 it was assumed that there was an unlimited amount of FRR replacing the FCR which had been used for balancing the system after generation trips of market induced unbalances. However, this assumption might not be correct in some cases as a control area within a synchronous system might not have FRR available which would imply that the FCR will continue to be deployed until the control area has FRR or RR available.

In order to estimate what is the effect of the availability of FRR on the risk calculations the Monte Carlo simulation for calculation of the used FCR due to generation trips have also been performed assuming that the probability of FRR to completely replace the used FCR due to an unbalance on that area is of 99 %, 98 %, 95 %, 90 % and 85 %. If the FRR in the control area where the unbalance occurred is not ready to replace the FCR it is assumed that the FCR is not begun to be replaced until 15 minutes later. In the meantime, the FCR used due to that specific trip is the power unbalance of that specific trip (Figure 19).

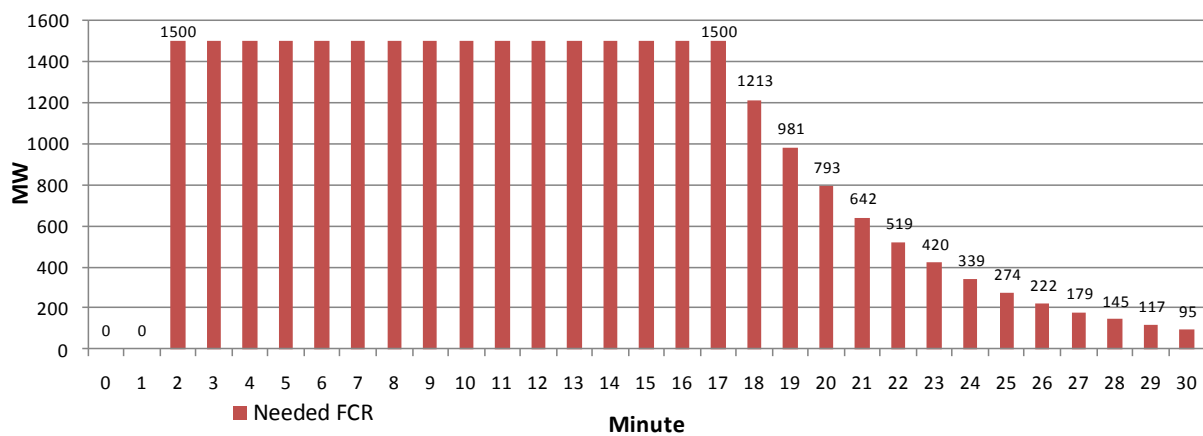

Figure 19: Example of used FCR in the Monte Carlo simulation if a unit of 1500 MW trips in minute 2 and is not replaced by the FRR in which the unbalance occurred assuming no other unbalances occur.

The results of this sensibility study on the risk of needing more than 3000 MW of FCR due to the combined effects of the generation trips and the market induced unbalances are shown in Figure 9 and in Table 5.

| Probability of deployment of FRR | Risk of needing more than 3000 MW of total FCR. Average events per year. | Risk of needing more than 3000 MW of total FCR. Years between events. |
|----------------------------------|--------------------------------------------------------------------------|-----------------------------------------------------------------------|
| 100 % | 0.015 | 68.8 |
| 99 % | 0.017 | 60.6 |
| 98 % | 0.018 | 54.4 |
| 95 % | 0.026 | 38.7 |
| 90 % | 0.049 | 20.3 |
| 85 % | 0.158 | 6.3 |

Table 5: Table 5Influence of FRR deployment.

As it can be seen in Table 5 the influence of the probability of deployment of FRR is significant. In fact as this probability is higher the impact increases exponentially (Figure 9). The results show that it should be assured with more than 90 % probability that the FRR will fully replace the used FCR due to a generation trip.

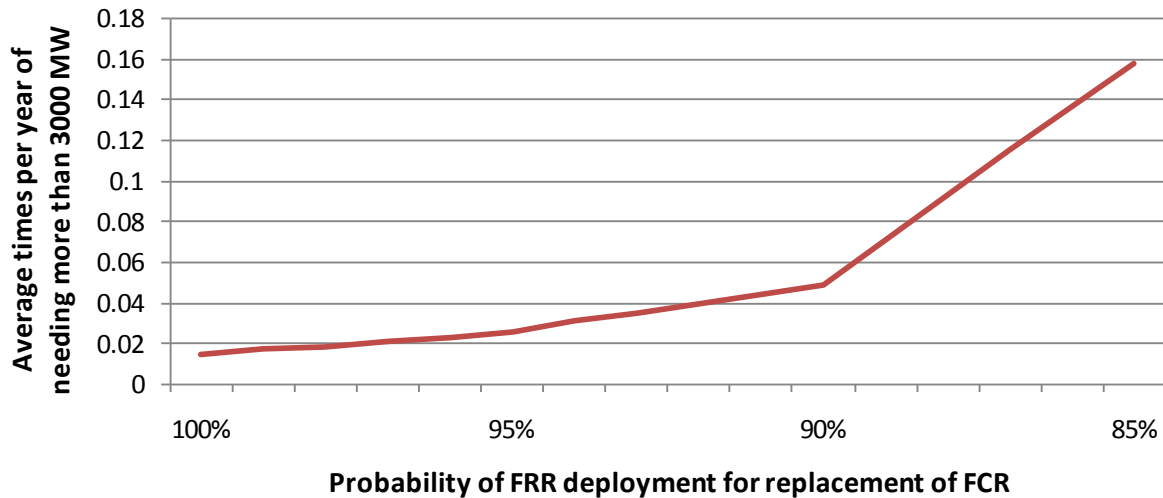

Figure 20: FRR deployment for replacement of FCR.

C.2.8. Calculations for Regional Group Nordic.

A similar study is performed also for Regional Group Nordic although there are significant differences in the amount of available FCR and how it is restored by the FRR.

A Monte Carlo simulation for a generation scenario for a peak moment is modelled with the units larger than 100 MW. It is assumed that the units are operating at full capacity and that when a unit trips it loses its full power and does not reconnect to the network within the next 15 minutes. The expected number of trips per year based on average historic data for each technology in RG CE corrected by the values of probability of unavailability of the unit at a given time is used as there is no data available about the number of trips per year in RG N. It is assumed that the probability of tripping of a certain unit is constant in time.

When a unit trips, it is assumed that the FCR recovers the balance of the system in the same minute as the deployment time of FCR and the system reaches a quasi-steady state. The effect of the FRR in the FCR is modelled considering that FRR deployment is manual and takes place between 6 and 20 minutes after the incident as it has been observed (Figure 21).

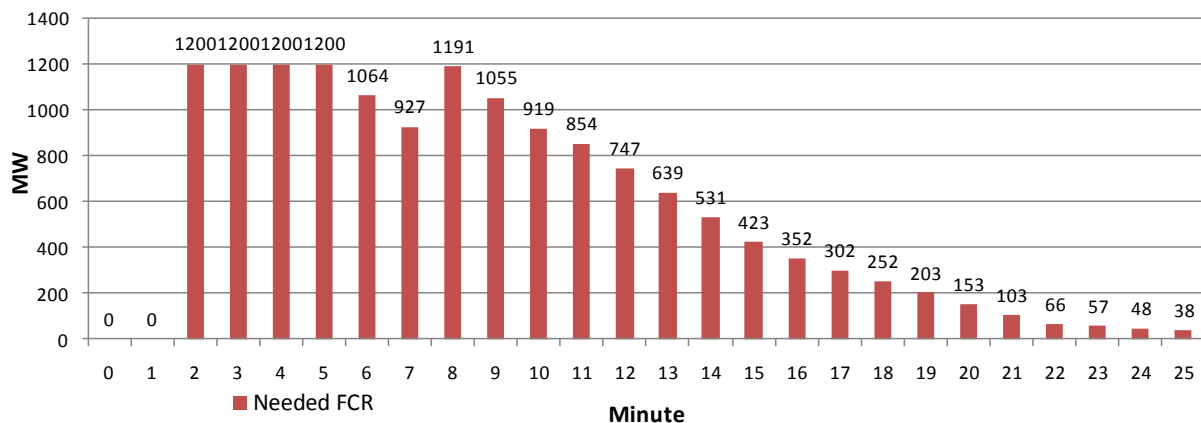

Figure 21: Example of used FCR in the Monte Carlo simulation if a unit of 1200 MW trips in minute 2 and a unit of 400 MW trips in minute 8.

The Monte Carlo simulation for the Nordic system is also run for 10^8 minutes or 190 years. The results are shown in Figure 22. The largest need for FCR registered in the 10^8 minutes was of 2580 MW.

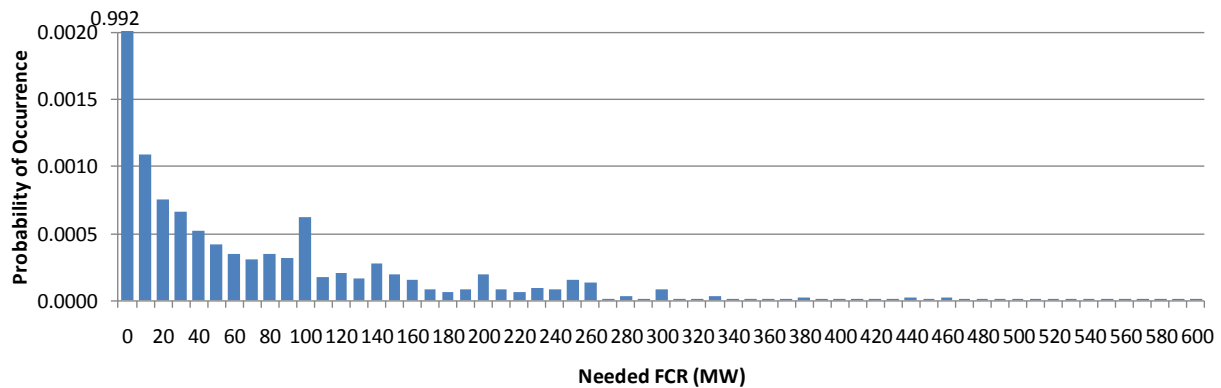

Figure 22: Probability distribution of the needed FCR in each minute in RG N due to generation trips from 0 to 600 MW.

The histogram of the used FCR in RG N shows that it is much more likely that there is no use of the FCR due to generation trips than in RG CE due to the smaller number of generators. The number of generators modelled was 166 compared to 840 generators in RG CE. Due to the activation of FRR and the amount of 100 MW hydro units in the model there are larger values like 100 MW that are more probable than smaller ones.

The FCR available in RG N is of 1600 MW, according to the simulations the RG N system would run out of FCR due to generation tripping 13 times in the 190 years or 1 in 14.6 years. This calculation does not take into account the self-regulation of loads.

As in RG N, like in RG CE, there are also other sources of unbalances and the market induced unbalances are also an undesirable source of unbalances. A similar methodology has been applied to calculate the risk associated to frequency deviations due to causes others than generation tripping. In this case, the effect of the self-regulation of loads, of 2.5 %/Hz is taken into account as its effect is quite significant.

It is assumed that the deployment of FCR is also linear with the frequency deviation. For frequency deviations of ± 100 mHz 600 MW of FCR are deployed. This results in -6000 MW/Hz. However assuming a self-regulation effect of loads of 2.5%/Hz and a system size of 40 GW there is an additional -1000 MW/Hz due to this self-regulation, totalling -7000 MW/Hz. As there is no record available for the studies of the minutes in which there were generation trips it is assumed that for 2010 all of the frequency deviations are due market induced unbalances.

As for RG CE the needed FCR is the sum of the needed FCR due to generation trips and the needed FCR due to market induced unbalances so the total needed FCR probability distribution function is obtained by means of the convolution of the both prior probability distribution functions. This function is shown for the example of the Nordic system in 2010 in **Error! Reference source not found.**

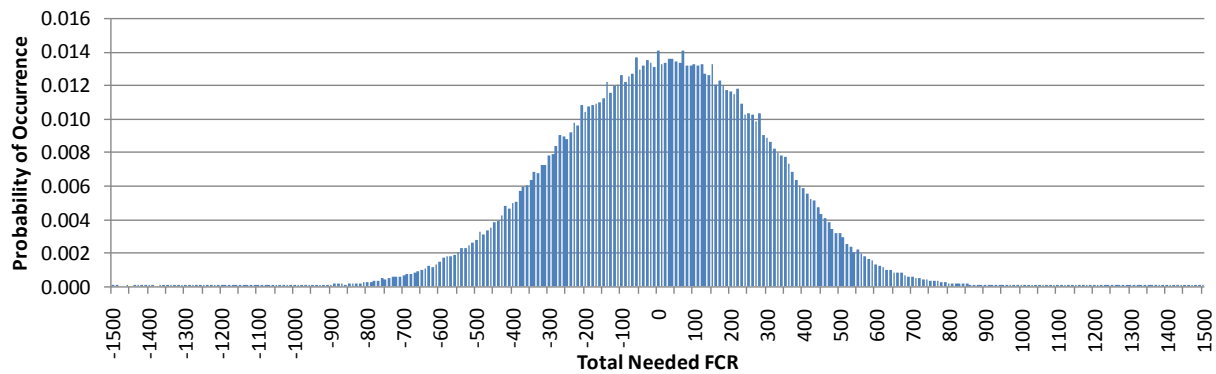

Figure 23: Probability distribution of the total FCR from -1500 to 1500 MW in RG CE.

Integrating the probability distribution of the total FCR from the available FCR to $+\infty$ the risk of needing more FCR than it is available can be obtained. The available FCR in the Nordic system is 1600 MW plus 200 MW due to the effect of the self-regulation of loads, totalling 1800 MW. The risk of needing more than 1800 MW of FCR plus self-regulation is of 0.00000236 or 1 in 0.82 years.

The risk of needing more than the available 1800 MW of FCR is considered quite high in RG Nordic, however in the last 10 years no significant incident has occurred. In reality, many hydro units are running in frequency mode which increases significantly in most cases the available FCR in RG Nordic and therefore decreases the risk of using all that is available. In addition, the HVDC interconnectors with RG Continental Europe are providing also frequency response for large frequency deviations in RG Nordic. These effects have not been taken into account in these probabilistic studies and the real risk is certainly much lower.

C.2.9. Calculations for Regional Group Ireland.

The same study has been performed for Regional Group Ireland taking into account the significant differences that apply to this island system.

A Monte Carlo simulation for a generation scenario for a peak scenario is modelled with the units larger than 100 MW. It is assumed that the units are operating at full capacity and that when a unit trips it loses its full power and does not reconnect to the network within the next 15 minutes. The expected number of trips per year for each unit is calculated on the basis of the average trips per year for each type of unit in RG CE, but adjusted to the number of trips for generation units over 100 MW in 2011.

When a unit trips in the Monte Carlo simulation, it is assumed that the FCR recovers the balance of the system in the same minute as the deployment time of FCR and the system reaches a quasi-steady state. The effect of the FRR in the FCR is modelled considering that FRR deployment is manual and takes place lineally between 1 and 15 minutes after the incident as it has been observed (Figure 24).

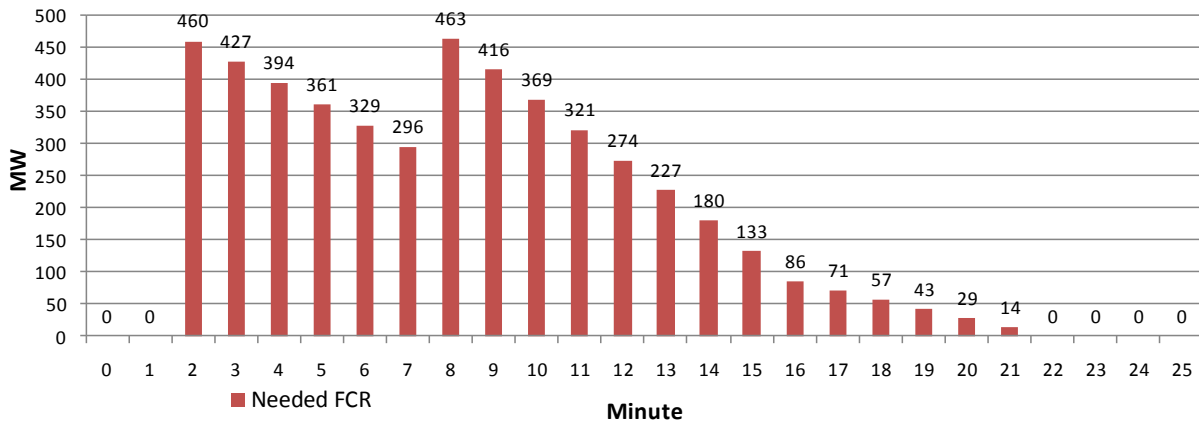

Figure 24: Example of used FCR in the Monte Carlo simulation if a unit of 460 MW trips in minute 2 and a unit of 200 MW trips in minute 8

The Monte Carlo simulation for the Irish system is also run for 10^8 minutes or 190 years. The results are shown in Figure 25. The largest need for FCR registered in the 10^8 minutes was of 520 MW.

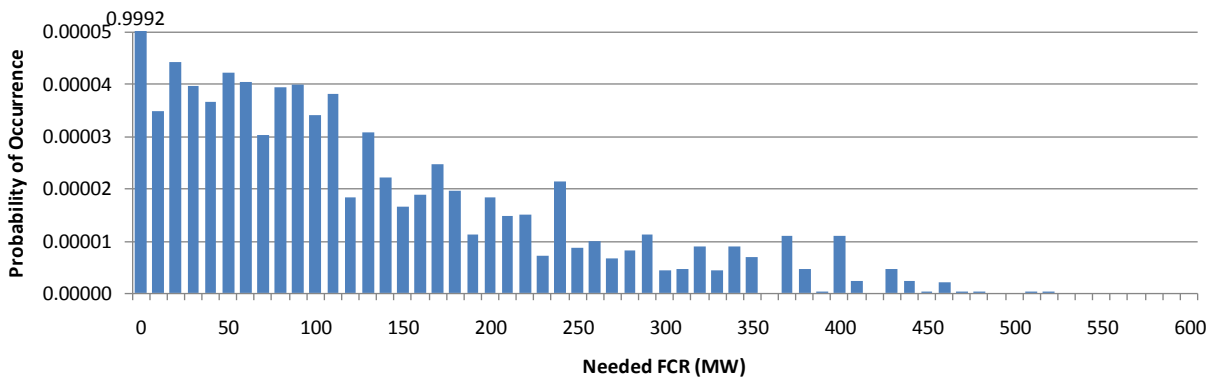

Figure 25: Probability distribution of the needed FCR in each minute in RG N due to generation trips from 0 to 600 MW.

The histogram of the used FCR in RG I shows that it is much more likely that there is no use of the FCR due to generation trips than in RG CE and RG N due to the much smaller number of generators. There were only 26 generators in the simulation, compared to 840 generators for RG CE. Another consequence of this small number of generators and of the manner in which FRR activation is modelled is that the probability of FCR use due to generation is quite irregular as some higher values may be more likely than other lower values.

The FCR available in RG N is of 470 MW, according to the simulations the RG I system would run out of FCR due to generation tripping 3 times in the 190 years or 1 in 63.3 years. This calculation does not into account the self-regulation of loads.

In RG I, like the in the other synchronous systems studied, there are also other sources of unbalances which add to the use of FCR and the same methodology has been applied to calculate the risk associated to frequency deviations due to causes others than generation tripping. In this case, the effect of the self-regulation of loads, of 1.5 %/Hz is taken into account as its effect is quite significant in the results.

It is also assumed that the deployment of FCR is also linear with the frequency deviation with a total network frequency characteristic of -500 MW/Hz. This value takes into account the effect of FCR and of the self-regulation of loads.

As for RG CE and RG N the needed FCR is the sum of the needed FCR due to generation trips and the needed FCR due to market induced unbalances so the total needed FCR probability distribution function is obtained by means of the convolution of the both prior probability distribution functions. This function is shown for the example of the Irish system in 2011 in Figure 26.

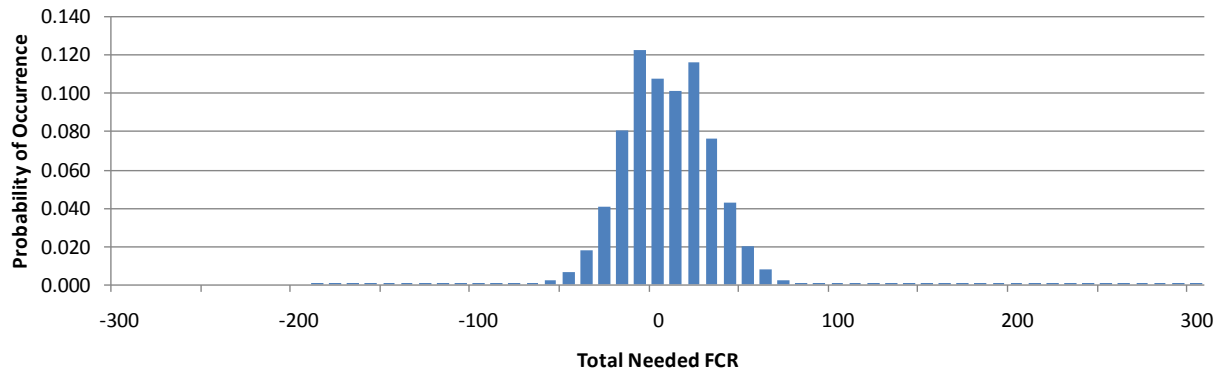

Figure 26: Probability distribution of the total FCR from -300 to 300 MW in RG CE.

It can be observed in Figure 12 that the probability of the convolution is much higher near the centre or the 0 value. This is a consequence of the size of the system, but also of the fact that the number and severity of the market induced unbalances is much lower than in RG N and RG CE.

Integrating the probability distribution of the total FCR from the available FCR to $+\infty$ the risk of needing more FCR than it is available can be obtained. The available FCR in the Irish system is 470 MW plus 90 MW due to the effect of the self-regulation of loads, totalling 560 MW. The risk of needing more than 560 MW of FCR plus self-regulation is of 0.00000023 or 1 in 8.25 years.

This risk has also been calculated varying the influence of the self-regulation effect of loads. If the self-regulation is 2 %/Hz instead of 1.5 %/Hz the effect can be taken into account assuming that there are 120 MW more FCR available. The risk of needing more than 590 MW of FCR plus self-regulation is of 0.00000021 or 1 in 9.41 years. If the self-regulation is 1 %/Hz, it can be only assumed that there is further 60 MW than the available FCR and the risk of needing more FCR than available increases to 0.00000030 or 1 in 6.46 years.

It must be noted however that it is believed that such a probabilistic methodology can't be directly applicable to smaller systems in which all of the generators are running in frequency responsive mode at all times without distinguishing which part of the available reserve in them is FCR and which part is FRR. The majority of generators in these systems will be dispatched to such a program that enables reserve provision.

Additionally, as it has been mentioned earlier in the document, these probabilistic studies assume that the system is able to always reach a quasi-steady state. In the case of smaller systems these assumption may be much more demanding than the availability of FCR during this quasi-steady state. Therefore the simulations for RG Ireland have been performed only for comparison with the larger systems and illustration purposes.

D. Impact analysis Initial Distribution FCR

Within the scope of the AhT OR calculations have been performed in order to assess the impact of a new model to determine the Initial Distribution of FCR. The results of those calculations, as well as the assumptions behind, are shown in this Annex.

Table 6⁹ shows the Initial Distribution of FCR for three scenarios. The share of FCR for each country is calculated by distributing 3000 MW of FCR based on:

- Net Generation¹⁰
- Consumption¹¹
- Net Generation and Consumption^{4,5}

| 2011 simulation | | | | | | | | | | | | | |
|--------------------------------|----|----|-----|----|----|----|-----|------|-----|-----|----|----|----|
| FCR [MW] | AT | BA | BE | BG | CH | CZ | DE | DK W | ES | FR | GR | HR | HU |
| Net Generation | 81 | 17 | 104 | 46 | 79 | 90 | 649 | 27 | 320 | 614 | 59 | 14 | 38 |
| Consumption | 79 | 13 | 101 | 39 | 76 | 74 | 635 | 25 | 312 | 586 | 64 | 21 | 46 |
| Net Generation and Consumption | 80 | 15 | 102 | 42 | 77 | 82 | 642 | 26 | 316 | 600 | 61 | 18 | 42 |

| 2011 simulation | | | | | | | | | | | | | |
|--------------------------------|-----|----|----|----|-----|-----|----|----|----|----|----|------|----|
| FCR [MW] | IT | LU | ME | MK | NL | PL | PT | RO | RS | SI | SK | UA W | AL |
| Net Generation | 333 | 4 | 3 | 7 | 128 | 166 | 56 | 63 | 49 | 17 | 29 | 8 | - |
| Consumption | 386 | 7 | 4 | 9 | 136 | 165 | 62 | 61 | 49 | 14 | 31 | 5 | - |
| Net Generation and Consumption | 359 | 6 | 4 | 8 | 132 | 165 | 59 | 62 | 49 | 15 | 30 | 6 | - |

Table 6: Table 5 Initial FCR distribution for three scenarios.

E. Current Situation concerning cross-border exchange of reserves in RGCE

Table 7 presents some examples of implementation for automatic reserve and manually activated reserve as well as the existing requirements in terms of security.

| FRR/RR | Cross-border exchange of capacity | Cross-border exchange of energy |
|---------------------------------------|------------------------------------------------------------------------------------------------------------------------------------------------------|----------------------------------------------------------------------------------------------------------------------------------------------------------------------------------------|
| Automatic reserve (secondary control) | Possible in RGCE (according to Policy 1) Limited possibilities of exchanges without transfer capacity reservation No example of implementation | <ul style="list-style-type: none"> • Possible without transfer capacity reservation (when NTC is available) • Example of implementation in RGCE: "ACE netting" |
| Manually activated reserve | Possible in RGCE (according to Policy 1) | <ul style="list-style-type: none"> • Possible without transfer capacity |

⁹ Results may differ from current Initial Distribution of FCR since bilateral agreements between countries are not taken into account. Production and Generation data can also differ slightly from current used values.

¹⁰ Based on production data from ENTSO-E data portal: <https://www.entsoe.eu/resources/data-portal/>. Production data of year Y-2 is used to calculate Initial FCR contributions for year Y.

¹¹ Based on Consumption data from ENTSOE data portal: <https://www.entsoe.eu/resources/data-portal/>. Consumption data of year Y-2 is used to calculate Initial FCR contributions for year Y.

| | | |
|-----------------------------------------------|------------------------------------------------------------------------------------------------------------------------------------------------------------------------------------------------------------------------------------------------------------------------------------------|----------------------------------------------------------------------------------------------------------------------------------------------------------------------------------------------------------------------------------------------------------------|
| | Limited possibilities of exchanges without transfer capacity reservation No example of implementation | reservation (when NTC is available) <ul style="list-style-type: none"> • Example of implementation in RGCE: BALIT (bilateral UK France share of unused surpluses of reserves that are not requested locally) • Nordic Balancing Market |
| Security requirements: Existing rules in RGCE | | |
| secondary control (included in FRR) | Transmission capacities across the subsequent borders must be available 66 % of the secondary control reserve needed are kept geographically within the control area 50 % of the total needed secondary control reserve plus tertiary reserve must be kept within the control area | No requirement (as long as the exchange is possible within the remaining NTC) |
| Manually activated reserve | 50 % of the total needed secondary control reserve plus tertiary reserve must be kept within the control area | No requirement (as long as the exchange is possible within the remaining NTC) |

Table 7: Examples for automatic and manually activated reserves Table 5.

F. ACE Target Values for RGCE

F.1. General formulas

Area Control Error of control area "i" is defined as:

$$ACE_i = \Delta P + \Delta f K_i$$

When we sum up all ACE_i throughout the whole synchronous area with "N" control areas we get:

$$ACE_T = \sum_{i=1}^N ACE_i = \sum_{i=1}^N \Delta P + \Delta f \sum_{i=1}^N K_i = \Delta f \sum_{i=1}^N K_i$$

If the frequency has mean μ_f and standard deviation σ_f for $K_T = \sum K_i$ we can write:

$$\begin{aligned} \mu_{ACE_T} &= \mu_{\Delta f} K_T \\ \sigma_{ACE_T} &= \sigma_{\Delta f} K_T \end{aligned}$$

With presumption, that ACE_i of control areas are independent, for standard deviation of whole synchronous area with "N" control areas we can write:

$$\sigma_{ACE_T} = \sqrt{\sum_{i=1}^N \sigma_{ACE_i}^2}$$

In reality there is some correlation of ACE_i between control areas. Table 8t shows correlation coefficients among different control areas calculated for sample data of 6 month of the year 2010. As seen from the table, correlations among control areas are weak, which allows us to use above mentioned formula.

| | AT | BE | CZ | DE | DK | ES | FR | IT | PL | RS |
|----|---------|---------|---------|---------|---------|---------|---------|---------|---------|---------|
| AT | 1 | -0,0576 | 0,0889 | -0,0977 | 0,0198 | 0,0553 | -0,0413 | -0,0778 | 0,0311 | -0,0302 |
| BE | -0,0576 | 1 | -0,0361 | 0,0627 | -0,0019 | -0,0463 | 0,0326 | 0,0511 | -0,0154 | 0,0183 |
| CZ | 0,0889 | -0,0361 | 1 | -0,2673 | 0,0719 | 0,1292 | -0,0892 | -0,0750 | 0,0622 | -0,0121 |
| DE | -0,0977 | 0,0627 | -0,2673 | 1 | -0,0512 | -0,1314 | 0,0745 | 0,1070 | -0,0687 | 0,0206 |
| DK | 0,0198 | -0,0019 | 0,0719 | -0,0512 | 1 | 0,0273 | -0,0357 | -0,0255 | 0,0129 | 0,0128 |
| ES | 0,0553 | -0,0463 | 0,1292 | -0,1314 | 0,0273 | 1 | -0,1828 | -0,0850 | 0,0477 | -0,0416 |
| FR | -0,0413 | 0,0326 | -0,0892 | 0,0745 | -0,0357 | -0,1828 | 1 | -0,0106 | -0,0187 | 0,0054 |
| IT | -0,0778 | 0,0511 | -0,0750 | 0,1070 | -0,0255 | -0,0850 | -0,0106 | 1 | -0,0416 | 0,0344 |
| PL | 0,0311 | -0,0154 | 0,0622 | -0,0687 | 0,0129 | 0,0477 | -0,0187 | -0,0416 | 1 | -0,0195 |
| RS | -0,0302 | 0,0183 | -0,0121 | 0,0206 | 0,0128 | -0,0416 | 0,0054 | 0,0344 | -0,0195 | 1 |

Table 8: Correlation of ACE between control areas Table 5.

F.2. Concept of open loop ACE

Open-loop ACE for one control area "i" is calculated as:

$$OLACE_i = ACE_i + \text{"All activated power reserves"}$$

And for relation between closed and opened loop ACE we also define:

$$ACE_i = c \cdot OLACE_i$$

Where "c" is a coefficient, representing expected (satisfactory) performance of load and frequency control. This performance is expected to be the same for all control areas. In reality there will be differences in load and frequency control performance among control areas, however control areas with weaker performance will tend to keep more power reserves in order to satisfy required control standards. Thus it is in the interest of each control area to perform adequately.

F.3. Concept of an elementary control area

We choose K-factor as metric for control area size and for the control area "i" we define:

$$m_i = K_i / K_0$$

Where:

- K_i is K-factor of control area "i"
- K_0 is K-factor of elementary control area
- m_i is relative size of control area "i", or also number of elementary areas inside particular control area.

Elementary area is virtual concept, used only for mathematical expression.
Size of K_0 does not matter.

There are two possible extreme situations:

1. power balance situation in all elementary areas inside one control area are 100 % correlated (inner correlation = 1)
2. power balance situation in all elementary areas inside one control area are independent (inner correlation = 0)

F.3.1. Case 1 "inner correlation = 1"

When elementary areas inside one control area are 100 % correlated, we can write for control area's ACEi:

$$\sigma_{ACE_i} = m_i \cdot c \cdot \sigma_{OLACE_0}$$

For whole synchronous area we can write:

$$\begin{aligned} \sigma_{ACE_T} &= \sqrt{\sum_{i=1}^N \sigma_{ACE_i}^2} = \sqrt{\sum_{i=1}^N (m_i \cdot c \cdot \sigma_{OLACE_0})^2} = c \cdot \sigma_{OLACE_0} \sqrt{\sum_{i=1}^N m_i^2} = c \cdot \frac{\sigma_{ACE_i}}{c \cdot m_i} \sqrt{\sum_{i=1}^N m_i^2} = \sigma_{ACE_i} \frac{\sqrt{\sum_{i=1}^N m_i^2}}{m_i} \\ &= \sigma_{ACE_i} \frac{\sqrt{\sum_{i=1}^N (K_i / K_0)^2}}{K_i / K_0} = \sigma_{ACE_i} \frac{\sqrt{\sum_{i=1}^N K_i^2}}{K_i} \end{aligned}$$

Expressing for one control area "i":

$$\sigma_{ACE_i} = \sigma_{ACE_T} \frac{K_i}{\sqrt{\sum_{i=1}^N K_i^2}}$$

F.3.2. Case 2 "inner correlation = 0"

When elementary areas inside one control area are not correlated (are independent), we can write for control area's ACE_i:

$$\sigma_{ACE_i} = \sqrt{m_i} \cdot c \cdot \sigma_{OLACE_0}$$

For whole synchronous area we can write:

$$\begin{aligned} \sigma_{ACE_T} &= \sqrt{\sum_{i=1}^N \sigma_{ACE_i}^2} = \sqrt{\sum_{i=1}^N (\sqrt{m_i} \cdot c \cdot \sigma_{OLACE_0})^2} = c \cdot \sigma_{OLACE_0} \sqrt{\sum_{i=1}^N m_i} = c \cdot \frac{\sigma_{ACE_i}}{c \cdot \sqrt{m_i}} \sqrt{\sum_{i=1}^N m_i} = \sigma_{ACE_i} \frac{\sqrt{\sum_{i=1}^N m_i}}{\sqrt{m_i}} \\ &= \sigma_{ACE_i} \frac{\sqrt{\sum_{i=1}^N (K_i/K_0)}}{\sqrt{K_i/K_0}} = \sigma_{ACE_i} \sqrt{\frac{\sum_{i=1}^N K_i}{K_i}} \end{aligned}$$

Expressing for one control area "i":

$$\sigma_{ACE_i} = \sigma_{ACE_T} \sqrt{\frac{K_i}{\sum_{i=1}^N K_i}} = \sigma_{ACE_i} \sqrt{\frac{K_i}{K_T}} = \sigma_{\Delta f} \sqrt{K_T K_i}$$

Thus we have relation between standard deviation of frequency deviations and standard deviation of Area Control Error.

G. Glossary

This glossary defines the terms used by the AHT OR in the compilation of this report.

| Term | Abb. | Definition |
|------------------------------------|-------------------|--------------------------------------------------------------------------------------------------------------------------------------------------------------------------------------------------------------------------------------------------------------------------------------------------------------------------------------------------------------------------------------------------------------------------------------------------------------------------------------------------------------------------------------------------------------------------|
| Activation delay of FCR | | Time delay between the occurrence of frequency deviations bigger than the activation deviation of FCR and the start of activation of FCR. |
| Area Control Error | ACE | The Area Control Error is the instantaneous difference between the actual and the reference value for the power interchange of a control area, taking into account the effect of the frequency bias for that control area according to the network power frequency characteristic of that control area, and of the overall frequency deviation. |
| Open Loop Area Control Error | ACE ^{OL} | The open loop ACE for a control area is an indicator of the total imbalance, and is the sum of the ACE for that control area and the activated reserves. |
| Tolerance range for FCR activation | | Frequency deviation at which the FCR activation is triggered at the latest. |
| Balance Responsible Party | | A party that has a contract proving financial security and identifying balance responsibility with the imbalance settlement responsible of the market balance area entitling the party to operate in the market. This is the only role allowing a party to buy or sell energy on a wholesale level. Additional information: The meaning of the word "balance" in this context signifies that that the quantity contracted to provide or to consume must be equal to the quantity really provided or consumed. Such a party is often owned by a number of market players. |
| Control area | | A control area is a coherent part of a synchronous area (usually coincident with the responsibility area of a TSO, a country or a geographical area) physically demarcated by the position of points for measurement of the interchanged power and energy to the remaining interconnected network. It is operated by a single TSO, which uses physical loads and controllable generation units to maintain and/or restore the balance between generation and demand within the <i>control area</i> . |
| Control Block | | The composition of one or more control areas working together to ensure the load frequency control |
| Control Energy | | See text in section 1.2.2. |
| Reserve providing unit | | A single entity (including a generating unit, controllable load or HVDC interconnector) that provides operational preserves |
| Dimensioning incident | | The maximum expected instantaneous power deviation due to an incident in a control area in Megawatt relevant for the dimensioning of the operational reserves. |
| Droop | PNC | The droop is one of the parameters set on the FCR controller. It is equal to the quotient of the relative quasi-steady-state frequency deviation on the network and the relative variation in power output from the FCR provider associated with the action of the FCR controller. This ratio without dimension is generally expressed as a percentage. |
| Electrical time deviation | | Time discrepancy between synchronous time and UTC |
| Frequency Containment Reserves | FCR | Frequency containment reserves are operating reserves necessary for constant containment of frequency deviations (fluctuations) from nominal value in order to constantly maintain the power balance in the whole synchronously interconnected system. Activation of these reserves results in a restored power balance at a frequency deviating from nominal value. This category includes operating reserves |

| | | |
|------------------------------------------|-----|---------------------------------------------------------------------------------------------------------------------------------------------------------------------------------------------------------------------------------------------------------------------------------------------------------------------------------------------------------------------------------------------------------------------------------------------------------------------------------------------------------------------------------------------------------------------------------|
| | | with the activation time typically of 30 s (depending on the specific requirements of the RG). Operating reserves of this category are usually activated automatically and locally. |
| Frequency Restoration Reserves | FRR | Frequency restoration reserves are operating reserves necessary to restore frequency to the nominal value and power balance to the scheduled value after sudden system imbalance occurrence. This category includes operating reserves with an activation time typically up to 15 minutes (depending on the specific requirements of the RG). Operating reserves of this category are typically activated centrally and can be activated automatically or manually. |
| FCR controller | | The FCR controller is decentralized / locally installed control equipment for a provider of FCR to control the active power output of the generator/load. In the case of synchronous generators it controls the valves of the turbine based on the speed of the generator |
| Frequency deviation | | Deviation of frequency from the nominal frequency. It can be negative or positive. |
| FRR Delay Time | | The period of time between the set point change from TSO and the commencement of FRR delivery. |
| Full Activation time of FCR | | Time period between the occurrence of the reference incident (idealized step-shaped) and the corresponding full activation of the FCR. |
| Full Activation Time of FRR | | Time period between the occurrence of an imbalance and the corresponding full activation of the FRR. |
| Generating Unit | | <p>A <i>generating unit</i> is an indivisible set of installations which can generate electrical energy. The <i>generating unit</i> may for example be a thermal power unit, a single-shaft combined-cycle plant, a single machine of a hydro-electric power plant, a wind turbine, a fuel cell stack, or a solar module.</p> <p>If there are more than one <i>generating units</i> within a power generating facility that cannot be operated independently from each other than each of the combinations of these units shall be considered as one <i>generating unit</i></p> |
| K-Factor | | The <i>K-Factor</i> is the estimated value introduced in an automatic FRR controller defining the dependency between the <i>synchronous system</i> frequency and deviation from power exchanges in the <i>control area</i> due to the expected activation of FCR within the <i>synchronous area</i> . It is usually given in megawatts per Hertz (MW/Hz). |
| Load Shedding | | Load shedding is the undesired disconnection of load from the synchronous area, usually performed automatically. |
| Maximum electrical time deviation | | The maximum deviation of the system time (the time integral of the system frequency) from the astronomical time (UCT), agreed by TSOs of the synchronous area. |
| Maximum frequency deviation | | Maximum expected instantaneous frequency deviation after the occurrence of a reference incident assuming predefined system conditions |
| Maximum steady-state frequency deviation | | Maximum expected frequency deviation at which the frequency oscillation after the occurrence of a reference incident stabilizes assuming predefined system conditions. |
| N-x (criterion) | | The N-x criterion is the rule according to which the elements remaining in operation after x failures of network elements (such as transmission line / transformer or generating unit, or in certain instances a bus-bar) must be capable of accommodating the change of flows in the network caused by that x number of failures. |

| | | |
|-------------------------------------------------|----|-------------------------------------------------------------------------------------------------------------------------------------------------------------------------------------------------------------------------------------------------------------------------------------------------------------------------------------------------------------------------------------------------------------------------------------------------------------------------------------------------------------------------------------------------------------------------------------------------------------------|
| Network power frequency characteristic | | The <i>network power frequency characteristic</i> defines the sensitivity, given usually in megawatts per Hertz (MW/Hz), which relates a <i>frequency deviation</i> to the amount of generation required to correct the power imbalance that has caused it. (or vice versa the stationary change of the frequency in case of a disturbance of the generation-load equilibrium); it is not to be confused with the K-factor. The network power frequency characteristic includes all active FCR and the <i>self-regulation of the load</i> and changes due to modifications in the load and generation pattern. |
| Nominal Frequency | | The rated value of the frequency for which all equipment connected to the electrical network is designed. |
| Operational reserves | OR | Active power reserves located in the generation units or loads to maintain balance between generation and demand and restore the frequency to its set point value in the synchronous system. Operational reserves are classified as Frequency Containment Reserves, Frequency Restoration Reserves and Replacement Reserves. |
| Reference Incident | | The maximum expected instantaneous power deviation due to an incident in the synchronous area in Megawatt for which the dynamic behaviour of the system is designed. |
| Replacement Reserves | RR | Replacement reserves are operating reserves used to restore the required level of operating reserves to be prepared for a further system imbalance. This category includes operating reserves with activation time from 15 minutes up to hours. |
| Set point | | A target value for any parameter typically used in control schemes. |
| Insensitivity range | | The tolerance for active power frequency contribution from a FCR provider to deliver FCR. |
| Self-Regulation of Load | | Load decrease expected in case of a frequency drop of 1 Hz |
| Standard frequency range | | Frequency range within which the system should be operated for defined time intervals. It is used as a basis for frequency quality analysis |
| Standard frequency criteria | | Maximum time intervals where the frequency of a synchronous area is allowed to be outside the standard frequency range without demand for remedial actions |
| Steady-State Stability (small signal stability) | | The ability of the electric system to withstand small changes or disturbances without the loss of synchronism among the synchronous machines in the system while having a sufficient damping of system oscillations (sufficient margin to the border of stability). |
| Synchronous area | SA | A set of synchronously interconnected elements that have no synchronous interconnections with other areas. Within a synchronous area the system frequency is common on a steady state. |
| System frequency | | The <i>system frequency</i> is the frequency in a <i>synchronous area</i> . |
| System Time Constant | | Time constant of the dynamic response of the synchronous system assuming it behaved as a first order filter after the occurrence of a generation-load unbalance. |
| Time to restore frequency | | Maximum expected time after the occurrence of a reference incident in which the frequency is restored inside the standard frequency range. |

| | | |
|------------------------|-----|---------------------------------------------------------------------------------------------------------------------------------------------------------------------------------------------------------------------------------------------------------------------------|
| Transient stability | | The ability of an electric system to maintain synchronism between its parts when subjected to a disturbance of specified severity and to regain a state of equilibrium following that disturbance. |
| System inertia | | The kinetic energy of the rotating masses connected to a synchronous area. |
| HVDC interconnector | | A High Voltage Direct Current (HVDC) line or facility connecting two synchronous areas. |
| Controllable load | | Load whose active power can be varied according to the synchronous area or TSO needs during normal operation. Load-shedding is not included. |
| Load frequency control | LFC | Control scheme created to maintain balance between generation and demand, to restore the frequency to its set point value in the synchronous area and, depending on the control structure in the synchronous area, to maintain the exchange power to its reference value. |
| Reserve receiving TSO | | The TSO responsible for the area which is receiving physically the operational reserves from outside its responsibility area. |
| Reserve connecting TSO | | The TSO responsible for the area where the reserve providing unit is located. |
| Reserve transiting TSO | | Any TSO through which the cross-border exchange reserves between a reserve connecting TSO and a reserve receiving TSO might flow. |

Table 9: GlossaryTable 5.